



HS - SERIES

SEMI-VORTEX - WASTEWATER PUMP

PERFORMANCE CURVE

MODEL	BORE	HP	kW	RPM	SOLIDS DIA.	LIQUID	SG.	VISCOSITY	TEMP.
HS(Z)3.75SL-62	3"/80mm	1	0.75	3411	0.28"/7mm	Water	1.0	1.123cSt.	60°F
PUMP TYPE	PHASE	VOLTAGE	AMPERAGE	HZ	STARTING METHOD	INS. CLASS			
Semi-Vortex - Wastewater Pump	1	115 / 230	9.7 / 4.9	60	Capacitor Start	E			
CURVE No.	DATE	PHASE	VOLTAGE	AMPERAGE	HZ	STARTING METHOD	INS. CLASS		
-	-	-	-	-	-	-	-		

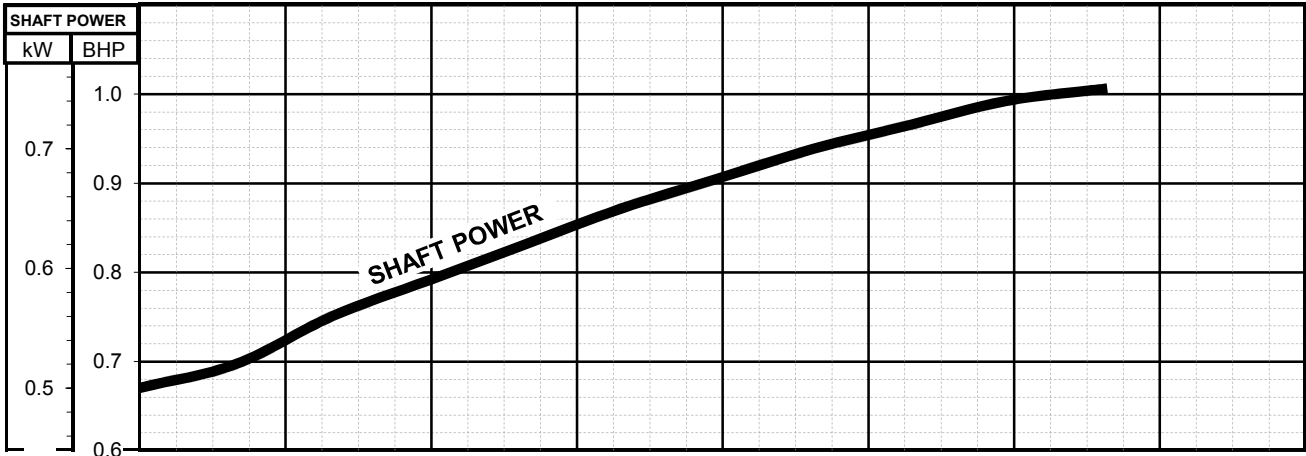
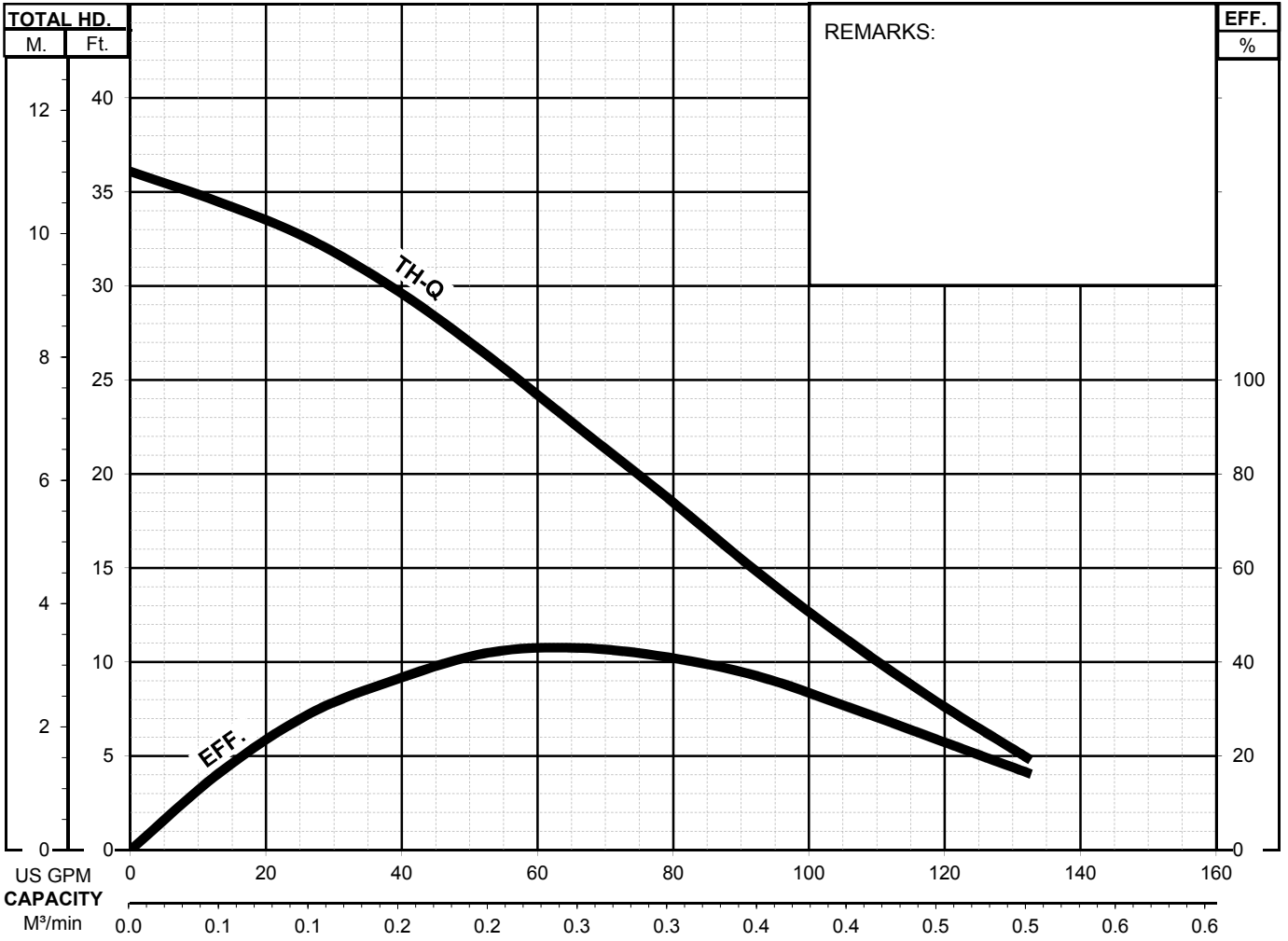

HSZ3.75SL-62

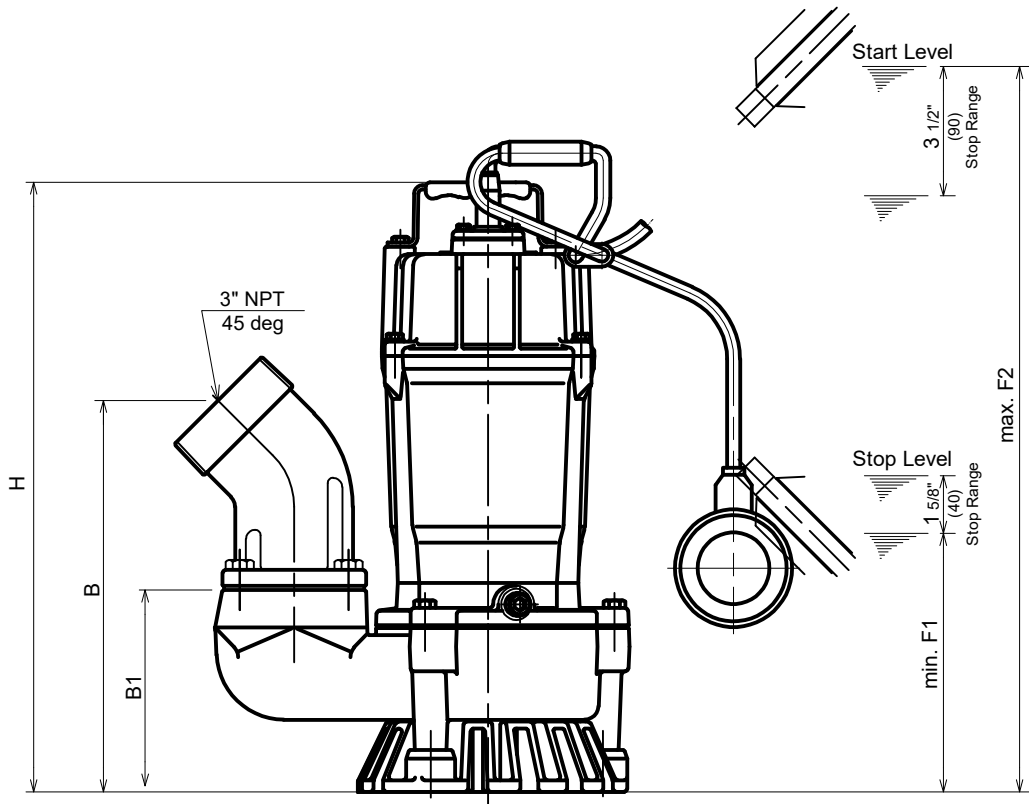
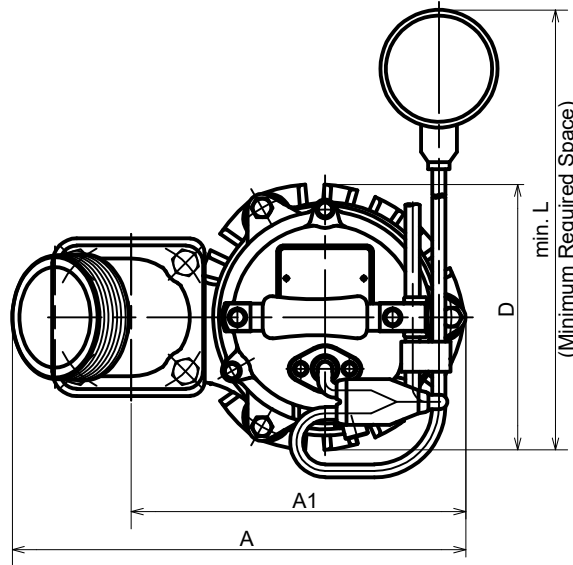

DIMENSIONS:USCS (Inch)

Model	HP	NOM. SIZE	Pump & Motor						Space	Stop	Start	Wt.* (lbs.)
			A	A1	B	B1	D	H	min. L	min. F1	max. F2	
HSZ3.75SL-62	1	3"	12 7/16	9 3/16	10 3/4	5 9/16	7 1/4	16 3/4	15 3/4	7 1/8	19 7/8	49

DIMENSIONS:METRIC (mm)

*Excluding Cable

Model	kW	NOM. SIZE	Pump & Motor						Space	Stop	Start	Wt.* (kg)
			A	A1	B	B1	D	H	min. L	min. F1	max. F2	
HSZ3.75SL-62	0.75	80	316	233	273	141	184	425	400	180	505	22.4

HSZ3.75SL-62

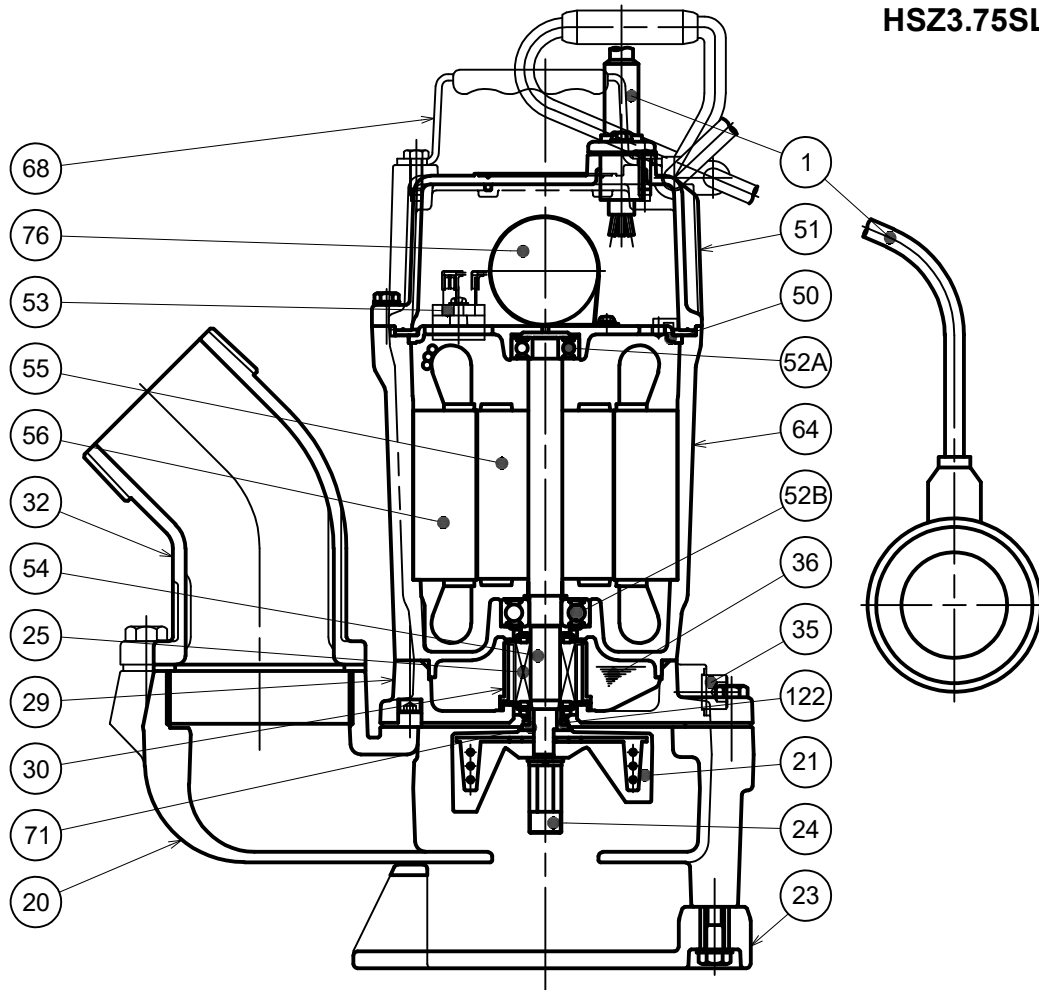

ITEM#	DESCRIPTION	MAIN MATERIAL / NOTE	RELATED ASTM, AISI CODE	RELATED EN CODE	Q'TY
1	Power Cable w/Float Set	PVC Sheath AWG14/3-32ft w/PP Resin + Chloroprene Sheath Cable			1
20	Pump Casing	Ductile Cast Iron	A536 100-70-03	EN 1563 GJS-700-2	1
21	Impeller	Urethane Rubber			1
23	Suction Strainer	PVC			1
24	Agitator	Steel	A283 Grade D	EN 10025 S275	1
25	Mechanical Seal	Silicon Carbide / W-14VL			1
29	Oil Casing	Ductile Cast Iron	A536 100-70-03	EN 1563 GJS-700-2	1
30	Oil Lifter	PBT Resin			1
32	Discharge Connection	Cast Iron /NPT 3"	A48M Class30B	EN 1561 GJL-200	1
35	Oil Plug	Stainless Steel	S 30400	1.4301	1
36	Lubricant	Turbine Oil ISO VG32 or SAE10W-20			
50	Motor Bracket	Aluminum Alloy Die Casting	B85 383.0	EN 1706 AC-46100	1
51	Motor Head Cover	Aluminum Alloy Die Casting	B85 383.0	EN 1706 AC-46100	1
52A	Upper Bearing	#6201ZZC3			1
52B	Lower Bearing	#6302ZZC3			1
53	Motor Protector				1
54	Shaft	Stainless Steel	S 40300	1.4000	1
55	Rotor				1
56	Stator				1
64	Motor Housing	Aluminum Alloy Die Casting	B85 383.0	EN 1706 AC-46100	1
68	Handle	Steel (Hot Rolled)+NR Rubber	A1011	EN 10111	1
71	Shaft Sleeve	Stainless Steel	S 30400	1.4301	1
76	Capacitor				1
122	V-Ring	Nitrile Butadiene Rubber			1