

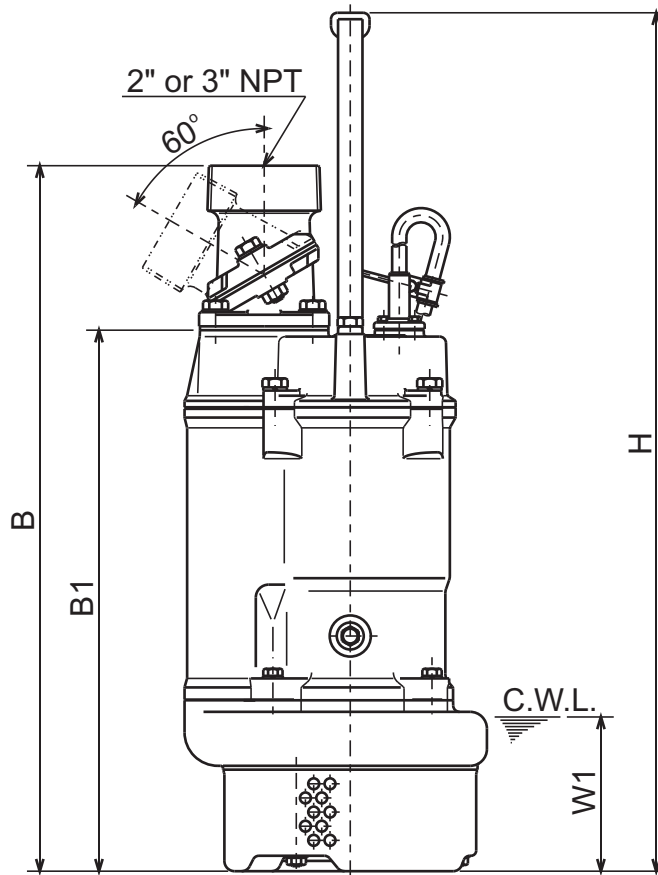

**KTZ - SERIES
DEWATERING PUMPS**

DIMENSIONS

**KTZ22.2-61
KTZ32.2-61**

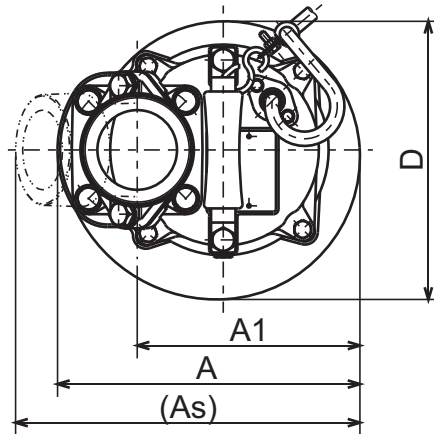

C.W.L. : Continuous running Water Level

DIMENSIONS:USCS (Inch)

Model	HP	NOM. SIZE	Pump & Motor							C.W.L.		Wt. (lbs.)
			A	As	A1	B	B1	D	H	W1		
KTZ22.2-61	3	2"	9 1/4	10 1/4	6 13/16	21 5/8	16 9/16	8 1/2	26 5/16	4 3/4	79	
KTZ32.2-61	3	3"	9 1/4	10 9/16	6 13/16	21 5/8	16 9/16	8 1/2	26 5/16	4 3/4	77	

DIMENSIONS:METRIC (mm)

Model	kW	NOM. SIZE	Pump & Motor							C.W.L.		Wt. (kg)
			A	As	A1	B	B1	D	H	W1		
KTZ22.2-61	2.2	50	235	261	173	549	421	216	668	120	36	
KTZ32.2-61	2.2	80	235	268	173	549	421	216	668	120	35	



KTZ - SERIES DEWATERING PUMPS

PERFORMANCE CURVE

MODEL	BORE	HP	KW	RPM	SOLIDS DIA	LIQUID	SG.	VISCOSITY	TEMP.
KTZ32.2-61	3"/80mm	3	2.2	3410	0.334"/8.5mm	Water	1.0	1.123 cSt.	60°F
PUMP TYPE	PHASE	VOLTAGE	AMPERAGE	HZ	STARTING METHOD	INS. CLASS			
Dewatering Pump	3	208-230/460/575	9.4-9.0 / 4.5 / 3.5	60	Direct On Line	F			
CURVE No.	DATE	PHASE	VOLTAGE	AMPERAGE	HZ	STARTING METHOD	INS. CLASS		
-	-	-	-	-	-	-	-		

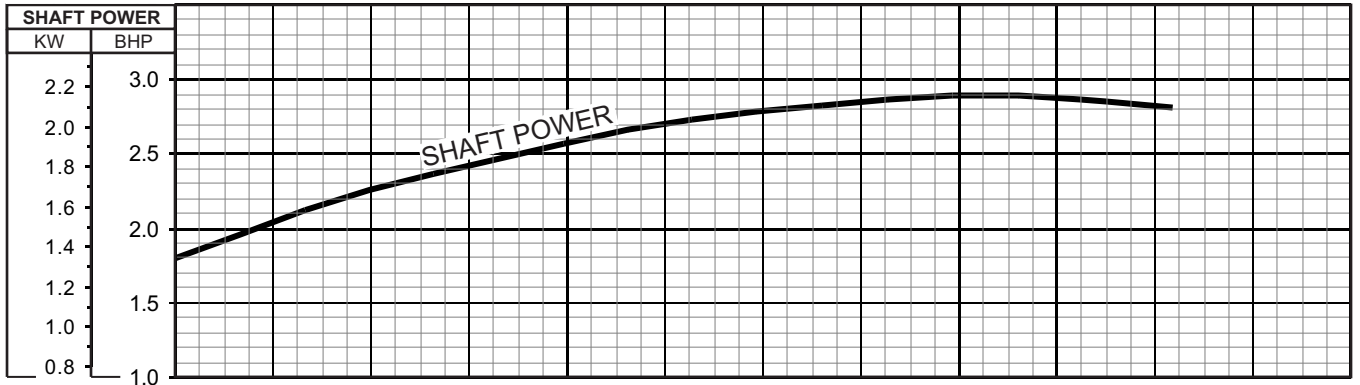
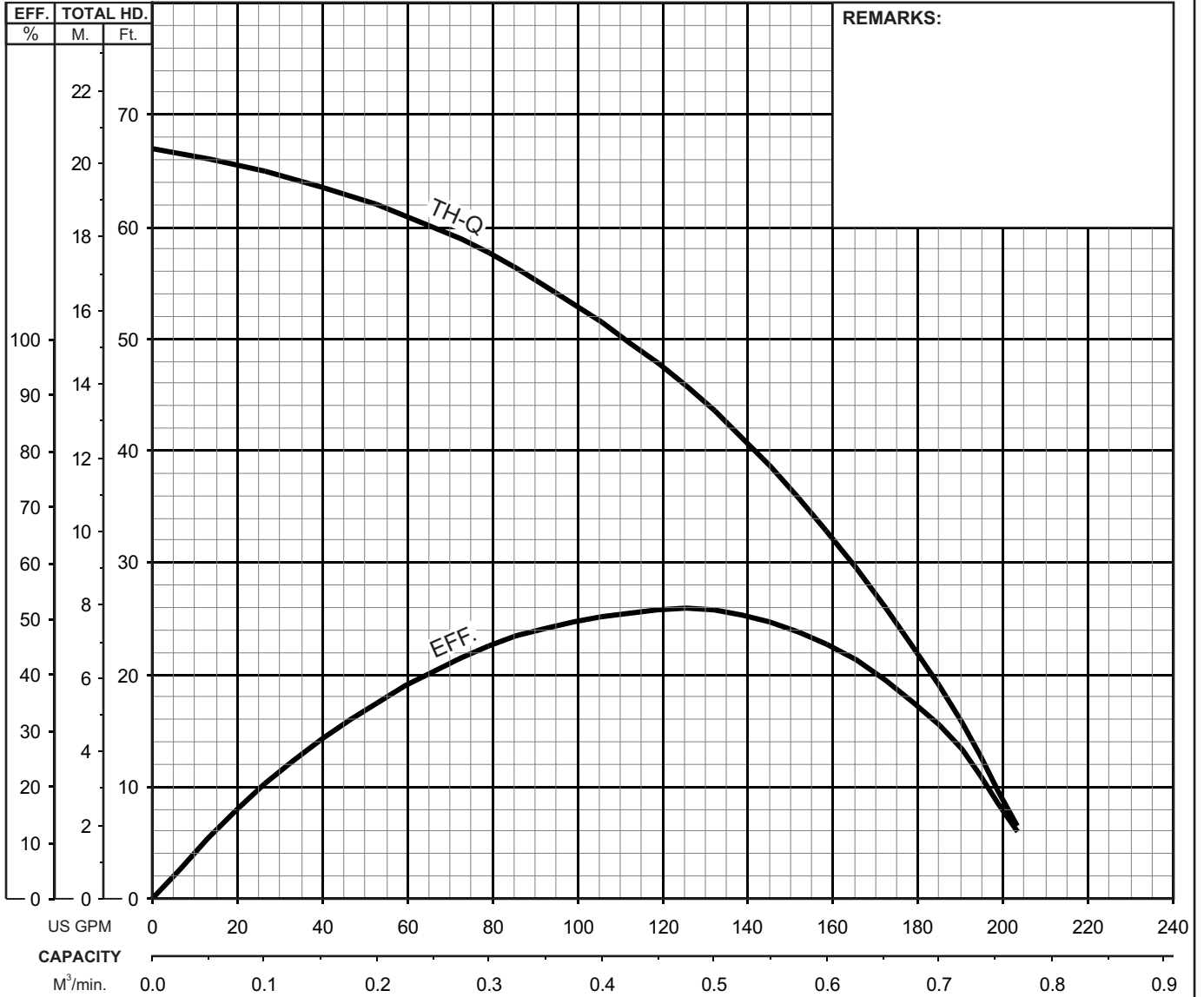

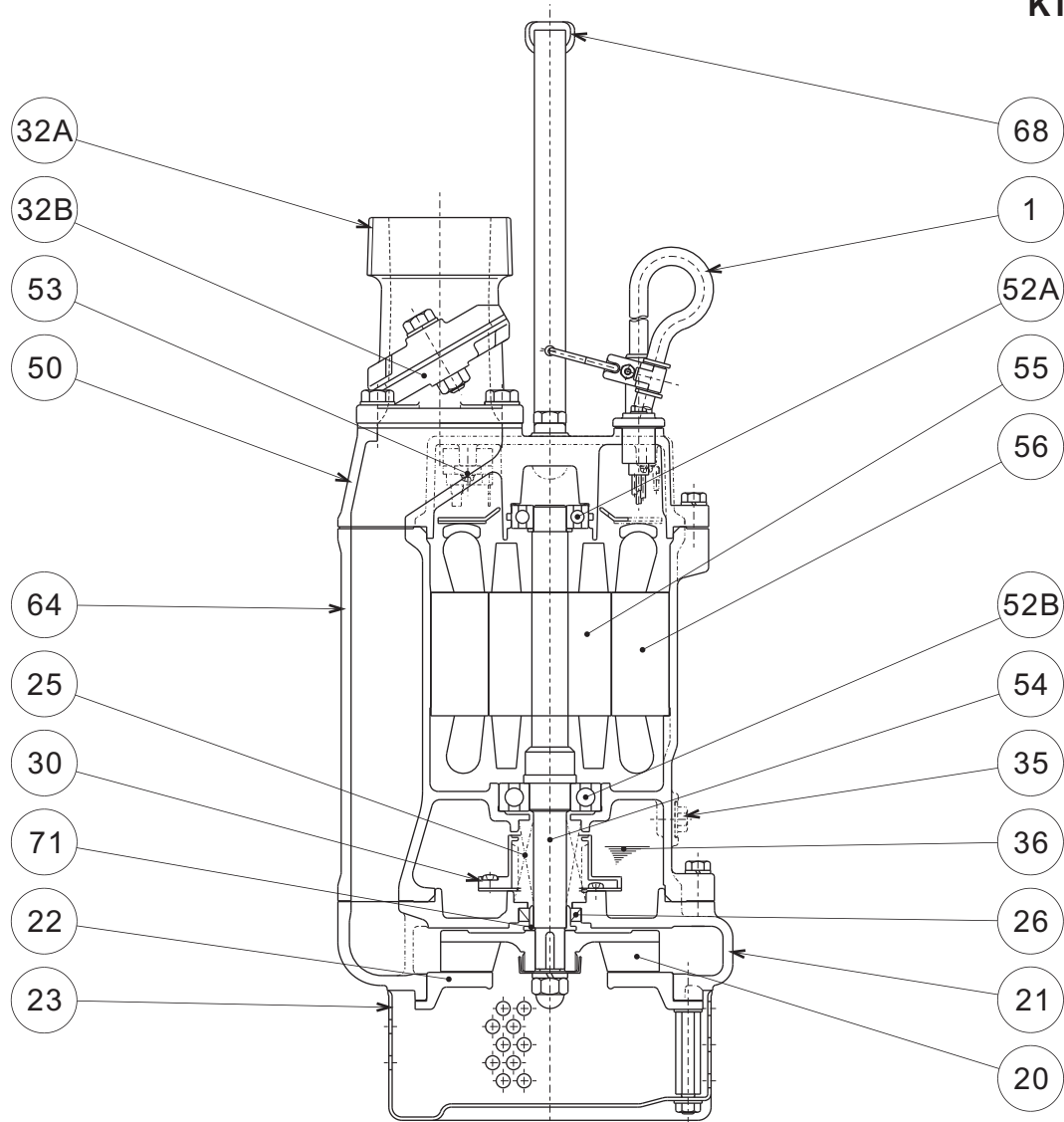
**TSURUMI PUMP**
**KTZ - SERIES
DEWATERING PUMPS**
SECTIONAL VIEW
**KTZ22.2-61
KTZ32.2-61**

ITEM#	DESCRIPTION	MAIN MATERIAL / NOTE	RELATED ASTM, AISI CODE	RELATED EN CODE	Q'TY
1	Power Cable	PVC Sheath AWG16/4-50ft			1
20	Pump Casing	Cast Iron	A48M Class30B	EN 1561 GJL-200	1
21	Impeller	High Chrome Cast Iron	A532 Class III Type A	DIN 1695 G-X260Cr27	1
22	Suction Cover	Ductile Cast Iron	A536 80-55-06	EN 1563 GJS-500-7	1
23	Suction Strainer	Steel (Cold Rolled)	A109/A1008	EN 10130	1
25	Mechanical Seal	Silicon Carbide / H-20T			1
26	Oil Seal	Nitrile Butadiene Rubber / TC-25388			1
30	Oil Lifter	PBT Resin			1
32A	Discharge Connection	Cast Iron / NPT 2" or 3"	A48M Class30B	EN 1561 GJL-200	1
32B	Attachment	Aluminum Alloy Die Casting	B85 383.0	EN 1706 AC-46100	1
35	Oil Plug	Stainless Steel	S 30400	1.4301	1
36	Lubricant	Turbine Oil ISO VG32 or SAE10W-20			
50	Motor Head Cover	Cast Iron	A48M Class25B	EN 1561 GJL-150	1
52A	Upper Bearing	#6204ZZC3			1
52B	Lower Bearing	#6305ZZC3			1
53	Motor Protector				1
54	Shaft	Stainless Steel	S 42000	1.4028	1
55	Rotor				1
56	Stator				1
64	Motor Housing	Cast Iron	A48M Class25B	EN 1561 GJL-150	1
68	Handle	Steel (Cold Rolled) + NBR Rubber	A109/A1008	EN 10130	1
71	Shaft Sleeve	Stainless Steel	S 30400	1.4301	1

PARTS LIST		CONTRACTOR PUMPS				8/11/2016
ITEM	PART No.	DESCRIPTION	QTY	SIZE	MATERIAL	NOTES
1	140-074-15	Hex.Bolt	2	M10x20	SUS304	
2	068-000-34	Handle	1	KTZ1.5/2.2	SPC+NBR	interchangable with OLD part# 068-000-17 (no TSURUMI logo)
3	010-126-17	Cable Clip Rubber	1	HS2	NBR	
4	010-105-10	Cable Clip	1	SB	SPC	
5	140-018-37	Hex.Bolt	1	M5x15	SWRM	
6	141-003-58	Hex.Nut	1	M5	SWRM	
7	140-427-17	Hex.Bolt (w/Plain Washer)	2	M5x15	SUS304	
8	003-190-10	Gland	1		SUS316	
9	001-803-33	Cabtyre Cable Set (50') 60Hz(USA)	1	VCT4Cx1.25mm2	LBT	
10	140-000-01	Hex.Bolt	4	M10x30(B=14)	SUS304	
11	142-128-24	Plain Washer	4	M10	SPC	
12	032-160-11	Hose Coupling	1	GH-15L(NPT-3)	FC	
13	121-181-17	Packing	1	KT-15	NBR	*
14	140-488-16	Hex.Bolt (w/Spring Washer)	4	M8x30	SUS304	
15	050-420-18	Motor Bracket	1		FC	
16	122-140-17	O-Ring	1	G-145(144.4xd3.1)	NBR	*
17	053-000-02	Motor Protector 220V-60Hz(USA)	1	KA313-GDVL103	(T.C)	
17	053-477-19	Motor Protector 440V-60Hz(USA)	1	KA313-GQXL104	(T.C)	
17	053-000-13	Motor Protector 575V-60Hz(USA)	1	KA311-DPZL78	(T.C)	
18	143-126-12	Pan Screw (w/Spring Washer/Plain Washer)	2	M4x12	SWRM	
19	009-292-11	Earth Terminal	1Set	1.25mmx140L		
20	143-085-34	Pan Screw (w/Spring Washer)	1	M4x6	C3604	
21	142-389-12	Wave Washer	1	6204	SK5	
22	052-103-18	Bearing	1	6204ZZC3		
23	122-293-16	O-Ring	1	47xd3.1	NBR	*
24	061-174-18	Slinger	1	d20xd27x2t	SPC	
25	058-000-13	Lead Wire Protection Plate	1	d61xd132x2t	Bakelite	
26	055-706-16	Rotor	1Set			
27	147-017-11	Impeller Key	1	5x5x20l	SUS420	
28	056-001-18	Stator 220V-60Hz(USA)	1Set			
28	056-001-19	Stator 440V-60Hz(USA)	1Set			
28	056-001-21	Stator 575V-60Hz(USA)	1Set			
29	052-108-13	Bearing	1	6305ZZC3		
30	121-507-13	Packing (Water Way, Upp.)	1	KTZ21.5/32.2	NBR	*
31	064-000-10	Motor Frame	1		FC	
32	140-488-16	Hex.Bolt (w/Spring Washer)	4	M8x30	SUS304	
33	121-246-11	Packing	1	d10.3xd16x2t	PE	*
34	035-125-13	Oil Plug	1	M10x20(B=13)	SUS304	

PARTS LIST		CONTRACTOR PUMPS				8/11/2016
ITEM	PART No.	DESCRIPTION	QTY	SIZE	MATERIAL	NOTES
35	025-243-17	Mechanical Seal	1	H-20T	SiC	
36	143-070-23	Pan Screw	2	M5x6	SWRM	
37	030-144-13	Oil Lifter	1	H-20(A)(T)	Resin	
38	143-070-10	Pan Screw	4	M5x6	SWRM	
39	030-154-16	Seal Stopper	1	H-20T	SPCC	
40	122-139-13	O-Ring	1	G-140(139.4xd3.1)	NBR	*
41	121-501-17	Packing (Water Way, Low.)	1	KTZ21.5/22.2	NBR	*
42	020-001-01	Pump Casing	1	KTZ21.5/32.2	FC	
43	026-105-19	Oil Seal	1	TC-25388	NBR	
44	071-314-13	Shaft Sleeve	1	d20xd25x16l	SUS304	
45	040-104-25	Impeller Shim		d18.2xd29x0.3t	SUS304	
46	021-552-23	Impeller (60Hz)	1	KTZ32.2-61	HiCrFC	
47	047-113-28	Impeller Thread Protect.Cover	1	No.3A(13.5)	SUS304	
48	142-165-10	Spring Washer	1	M12	SUS304	
49	141-032-14	Hex.Cap Nut	1	M12	SUS304	
50	120-110-12	Packing (S.Cover)		d150xd186x0.3t	PE	
51	022-000-53	Suction Cover	1	KTZ31.5/32.2	FCD	
52	142-127-23	Plain Washer	3	M8	SPC	
53	144-000-56	Stud Bolt	3	M8x85(12/30)	SUS410	interchangeable with OLD part# 144-492-15
54	023-472-11	Strainer Stand	1	KTZ21.5/32.2	SPCC	
55	142-127-23	Plain Washer	3	M8	SPC	
56	141-005-89	Hex.Nut	3	M8	SWRM	
	173-513-13	Packing O-Ring Set	1Set	(Marked by *)		
13	121-181-17	Packing (Hose Coupling)	1	KT-15	NBR	*
16	122-140-17	O-Ring (M.Bracket/M.Frame)	1	G-145(144.4xd3.1)	NBR	*
23	122-293-16	O-Ring (Upp. Bearing)	1	47xd3.1	NBR	*
30	121-507-13	Packing (Water Way, Upp.)	1	KTZ21.5/32.2	NBR	*
33	121-246-11	Packing (Oil Plug)	1	d10.3xd16x2t	PE	*
40	122-139-13	O-Ring (M.Frame/P.Casing)	1	G-140(139.4xd3.1)	NBR	*
41	121-501-17	Packing (Water Way, Low.)	1	KTZ21.5/22.2	NBR	*
		Lubricant		Turbine Oil VG32 740ml		
	183-008-11	Impeller Puller	1	A No.3 1"	FC	

PARTS LIST		CONTRACTOR PUMPS				8/11/2016
ITEM	PART No.	DESCRIPTION	QTY	SIZE	MATERIAL	NOTES

EXPLODED VIEW

KTZ31.5-51/61
KTZ32.2-51/61

