

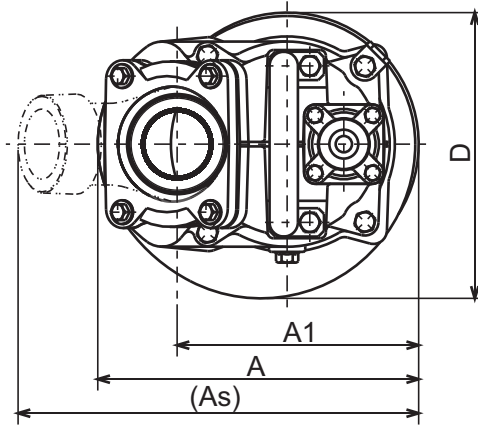

**KTZ - SERIES
DEWATERING PUMPS**

DIMENSIONS



**KTZ23.7-63
KTZ33.7-63
KTZ43.7-63**

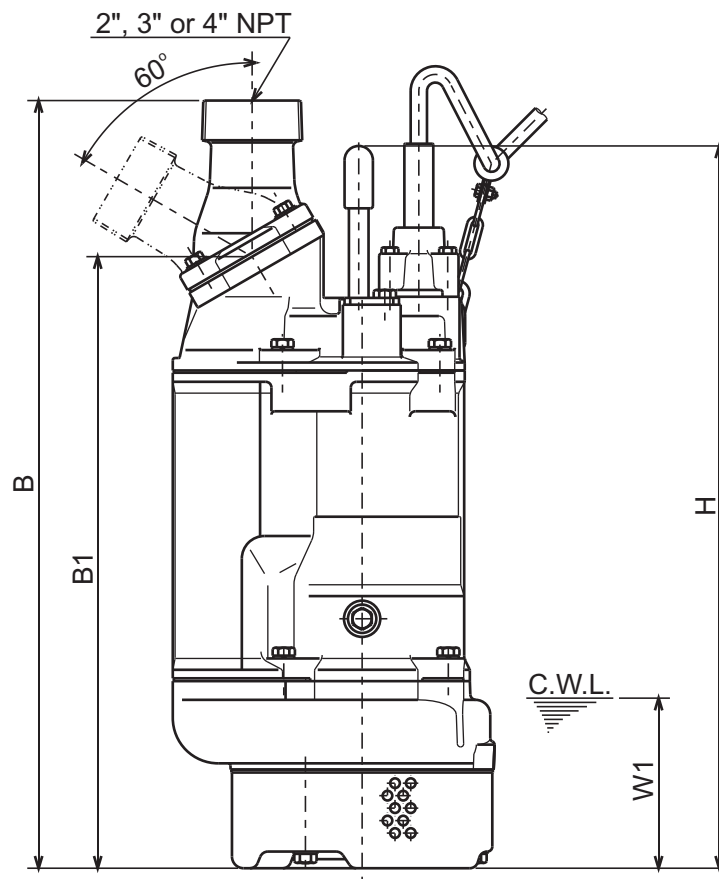

C.W.L. : Continuous running Water Level

DIMENSIONS:USCS (Inch)

Model	HP	NOM. SIZE	Pump & Motor							C.W.L.	Wt.
			A	As	A1	B	B1	D	H	W1	(lbs.)
KTZ23.7-63	5	2"	11 1/8	13 5/16	8 3/8	26 1/4	21 1/4	9 15/16	25 1/16	5 7/8	137
KTZ33.7-63	5	3"	11 1/8	13 7/8	8 3/8	26 5/8	21 1/4	9 15/16	25 1/16	5 7/8	137
KTZ43.7-63	5	4"	11 1/8	14 1/2	8 3/8	27 1/16	21 1/4	9 15/16	25 1/16	5 7/8	137

DIMENSIONS:METRIC (mm)

Model	kW	NOM. SIZE	Pump & Motor							C.W.L.	Wt.
			A	As	A1	B	B1	D	H	W1	(kg)
KTZ23.7-63	3.7	50	283	337	213	667	539	252	637	150	62
KTZ33.7-63	3.7	80	283	353	213	677	539	252	637	150	62
KTZ43.7-63	3.7	100	283	368	213	687	539	252	637	150	62



KTZ - SERIES DEWATERING PUMPS

PERFORMANCE CURVE

MODEL	BORE	HP	KW	RPM	SOLIDS DIA	LIQUID	SG.	VISCOSITY	TEMP.
KTZ33.7-63	3"/80mm	5	3.7	3410	0.334"/8.5mm	Water	1.0	1.123 cSt.	60°F
PUMP TYPE	PHASE	VOLTAGE	AMPERAGE	HZ	STARTING METHOD	INS. CLASS			
Dewatering Pump	3	208-230/460/575	15.0-13.6 / 6.8 / 5.3	60	Direct On Line	F			
CURVE No.	DATE	PHASE	VOLTAGE	AMPERAGE	HZ	STARTING METHOD	INS. CLASS		
-	-	-	-	-	-	-	-		

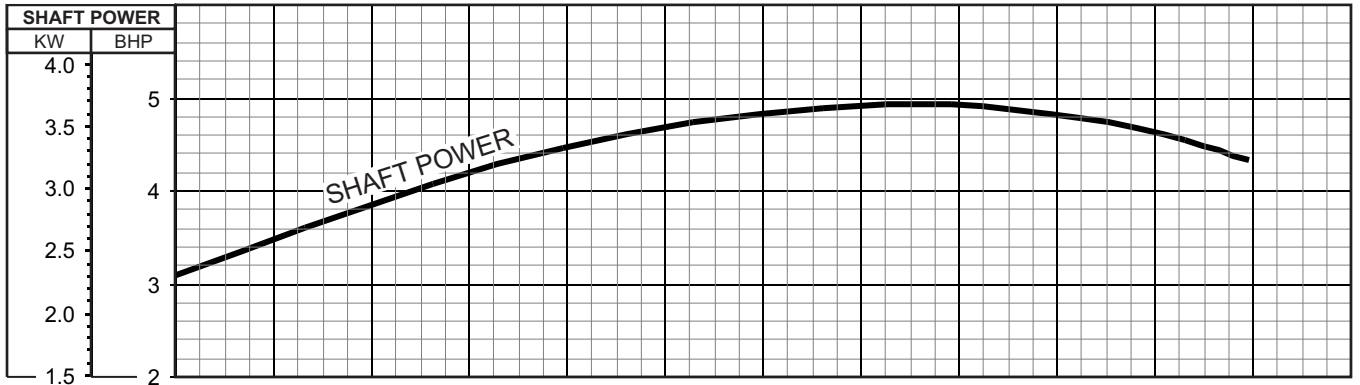
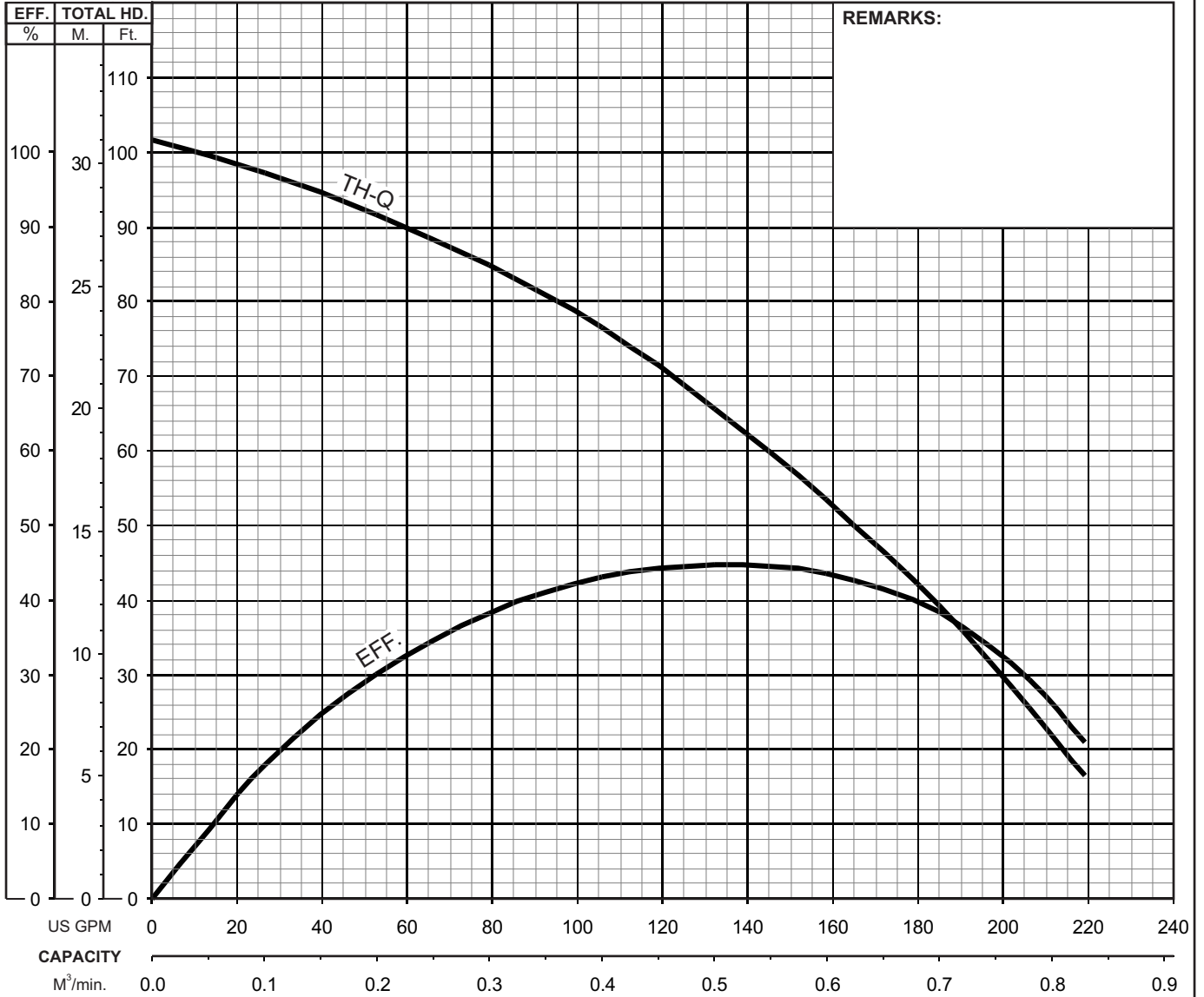

**KTZ23.7-63
KTZ33.7-63
KTZ43.7-63**

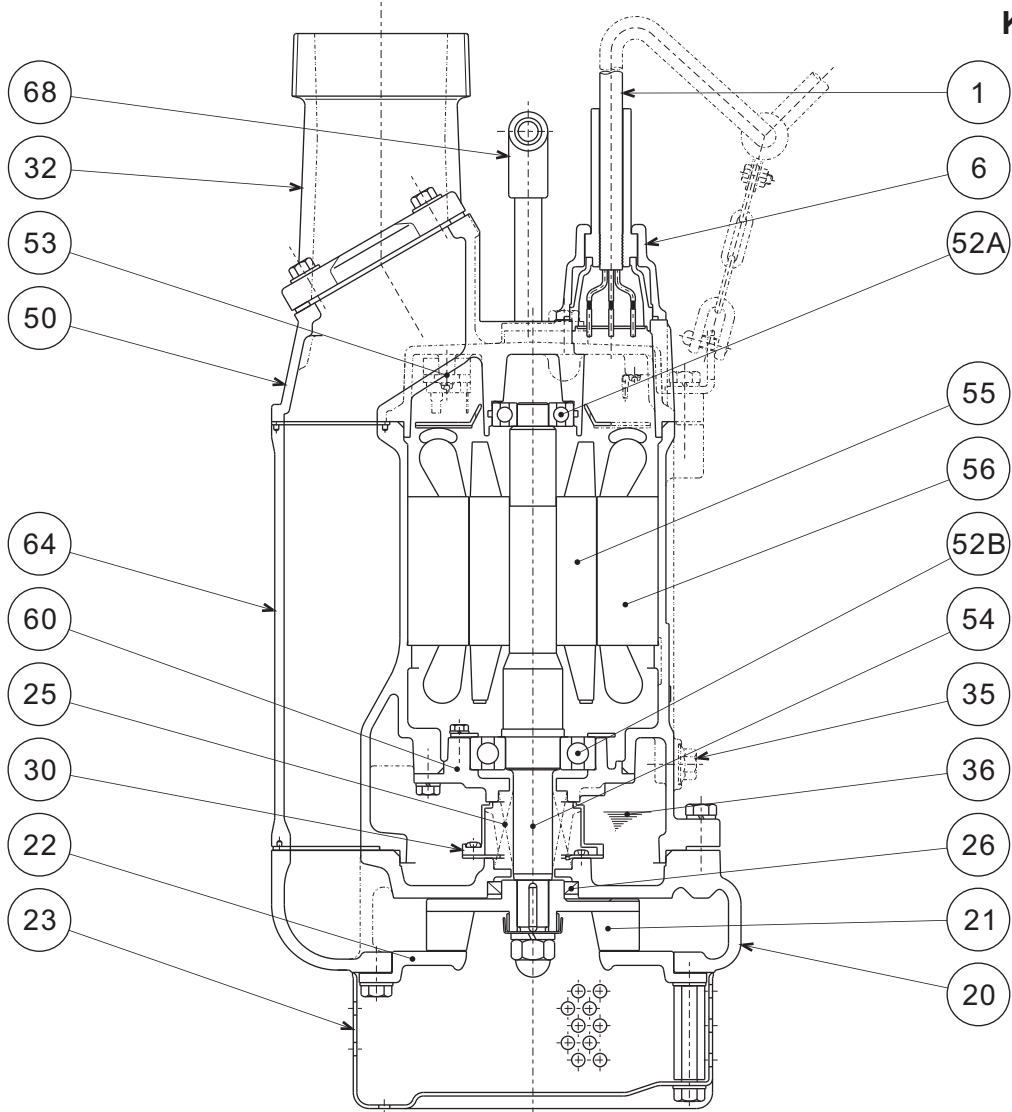

ITEM#	DESCRIPTION	MAIN MATERIAL / NOTE	RELATED ASTM, AISI CODE	RELATED EN CODE	Q'TY
1	Power Cable	Chloroprene Sheath AWG14/4-50ft			1
6	Stuffing Box	Cast Iron	A48M Class30B	EN 1561 GJL-200	1
20	Pump Casing	Cast Iron	A48M Class30B	EN 1561 GJL-200	1
21	Impeller	High Chrome Cast Iron	A532 Class III Type A	DIN 1695 G-X260Cr27	1
22	Suction Cover	Ductile Cast Iron	A536 80-55-06	EN 1563 GJS-500-7	1
23	Suction Strainer	Steel (Cold Rolled)	A109/A1008	EN 10130	1
25	Mechanical Seal	Silicon Carbide / H-25T			1
26	Oil Seal	Nitrile Butadiene Rubber / TC-40588			1
30	Oil Lifter	PBT Resin			1
32	Discharge Connection	Cast Iron / NPT 2", 3" or 4"	A48M Class30B	EN 1561 GJL-200	1
35	Oil Plug	Stainless Steel	S 30400	1.4301	1
36	Lubricant	Turbine Oil ISO VG32 or SAE10W-20			
50	Motor Head Cover	Cast Iron	A48M Class25B	EN 1561 GJL-150	1
52A	Upper Bearing	#6304ZZC3			1
52B	Lower Bearing	#6307ZZC3			1
53	Motor Protector				1
54	Shaft	Stainless Steel	S 42000	1.4028	1
55	Rotor				1
56	Stator				1
60	Bearing Housing	Cast Iron	A48M Class25B	EN 1561 GJL-150	1
64	Motor Housing	Cast Iron	A48M Class25B	EN 1561 GJL-150	1
68	Handle	Carbon Steel Pipe + NBR Rubber	A53 Type F	DIN 1615 St33	1

PARTS LIST		DEWATERING PUMP				11/8/2019
ITEM	PART No.	DESCRIPTION	QTY	SIZE	MATERIAL	NOTES
1	140-074-15	Hex.Bolt	2	M10x20	SUS304	
2	068-000-36	Handle	1	KTZ23.7/45.5	SGP+SS	
3	010-124-15	Cable Clip Rubber	1	No.3	NBR	
4	010-120-18	Cable Clip	1	No.2-1	SPC	
5	140-032-37	Hex.Bolt	1	M6x15	SWRM	
6	141-004-59	Hex.Nut	1	M6	SWRM	
7	095-000-95	Chain	1	4mm(4L)	SS	replaces OLD# 095-131-18 (3L)
8	011-110-11	Shackle	1	6mm(M8,SC)	SS	
9	001-840-32	Cabletyre Cable Set (50')208-575V-60Hz(USA)	1	2PNCTF4Cx2mm2	KTZ	
10	140-060-18	Hex.Bolt	4	M8x50	SUS304	
11	006-167-17	Stuffing Box	1	No.1-3	FC	included in ITEM# 9 Cable Ass'y
12	122-121-12	O-Ring	1	G-50(49.4xd3.1)	NBR	*
13	004-167-11	Cable Bush	1	No.1	CR	included in ITEM# 9 Cable Ass'y
14	008-156-19	Mould Cover	1	No.1-3	ADC	included in ITEM# 9 Cable Ass'y
15	009-126-13	Terminal	4	1.25mm2/2mm2	Nylon	included in ITEM# 9 Cable Ass'y
16	002-135-14	Heat Shrink Tube (Sold per meter)	m	A(d15x0.3t)	(Vm)	
17	140-000-87	Hex.Bolt	4	M10x35(B=14)	SUS304	
18	142-128-24	Plain Washer	4	M10	SPC	
19	032-000-92	Hose Coupling	1	KTZ33.7-63(NPT-3,Angle)	FC	
20	121-001-48	Packing	1	KTZ-3.7/7.5(Angle)	NBR	*
21	140-079-10	Hex.Bolt	4	M10x40	SUS304	
22	142-164-19	Spring Washer	4	M10	SUS304	
23	070-117-11	L-Shape Fitting	1	40x25x4.5t d13Hole	SPC	
24	050-001-06	Motor Bracket	1		FC	
25	122-276-13	O-Ring	1	160xd3.1	NBR	*
26	053-241-25	Motor Protector 208/230V-60Hz(USA)	1	KA313-GGXL110	(T.C)	
	053-000-02	Motor Protector 460V-60Hz(USA)	1	KA313-GDVL103	(T.C)	
	053-421-18	Motor Protector 575V-60Hz(USA)	1	KA313-GQXL102	(T.C)	
27	143-126-12	Pan Screw (w/Spring Washer/Plain Washer)	2	M4x12	SWRM	
28	009-293-12	Earth Terminal	1Set	2mm2x180L		
29	143-085-21	Pan Screw (w/Spring Washer)	1	M4x6	SWRM	
30	142-196-10	Wave Washer	1	6205/6304	SK5	
31	052-107-12	Bearing	1	6304ZZC3		
32	122-367-12	O-Ring	1	52xd3.1	NBR	*
33	058-000-04	Lead Wire Protection Plate	1	d66xd150x1.5t	Bakelite	
34	055-002-82	Rotor	1Set			
35	147-026-13	Impeller Key	1	5x5x25L	SUS420	
36	056-001-27	Stator 208/230V-60Hz(USA)	1Set			

PARTS LIST		DEWATERING PUMP			11/8/2019	
ITEM	PART No.	DESCRIPTION	QTY	SIZE	MATERIAL	NOTES
	056-001-29	Stator 460V-60Hz(USA)	1Set			
	056-001-31	Stator 575V-60Hz(USA)	1Set			
37	121-506-12	Packing (Water Way, Upp.)	1	KTZ23.7/33.7/43.7	NBR	*
38	064-000-19	Motor Frame	1		FC	
39	140-078-19	Hex.Bolt	4	M10x35	SUS304	
40	142-164-19	Spring Washer	4	M10	SUS304	
41	121-247-12	Packing	1	d12.3xd18x2t	PE	*
42	140-000-17	Hex.Bolt (w/Flange)	1	M12x15(Oil Plug)	SUS304	
43	140-000-23	Hex.Bolt (w/Spring Washer)	4	M5x10	SWRM	
44	062-000-02	Bearing Cover	4	d5.5xd18x2t	SPC	
45	052-110-18	Bearing	1	6307ZZC3		
46	122-133-17	O-Ring	1	G-110(109.4xd3.1)	NBR	*
47	060-001-76	Bearing Housing	1		FC	
48	142-163-34	Spring Washer	4	M8	SWRH	
49	140-054-48	Hex.Bolt	4	M8x20	SWRM	
50	025-001-00	Mechanical Seal	1	H-25T (RoHS)	SiC	supercedes 025-000-07
51	143-070-23	Pan Screw	2	M5x6	SWRM	
52	030-143-12	Oil Lifter	1	H-25(A)(T)	Resin	
53	143-070-10	Pan Screw	4	M5x6	SWRM	
54	030-148-17	Seal Stopper	1	HT-2530	SPCC	
55	122-283-13	O-Ring	1	165xd3.1	NBR	*
56	121-124-12	Packing (Water Way, Low.)	1	KTV-37/55	NBR	*
57	020-001-02	Pump Casing	1	KTZ23.7/33.7/43.7	FC	
58	026-144-49	Oil Seal	1	TC-40588	NBR	
59	040-106-27	Impeller Shim		d20.2xd30x0.3t	SUS304	
60	021-L17-18	Impeller (60Hz)	1	KTZ33.7-63	HiCrFC	
	021-L16-17	Impeller (50Hz)	1	KTZ33.7-53	HiCrFC	
61	047-104-26	Impeller Thread Protect.Cover	1	No.3B(18)	SUS304	
62	142-166-11	Spring Washer	1	M16	SUS304	
63	141-033-15	Hex.Cap Nut	1	M16	SUS304	
64	120-109-21	Packing (S.Cover)		d180xd222x0.5t(d12)	PE	
65	022-000-55	Suction Cover	1	KTZ33.7/35.5	FCD	
66	142-128-24	Plain Washer	3	M10	SPC	
67	140-074-15	Hex.Bolt	3	M10x20	SUS304	
68	142-128-24	Plain Washer	3	M10	SPC	
69	144-000-31	Stud Bolt	3	M10x94(20/14)	SUS410	
70	023-471-10	Strainer Stand	1	KTZ23.7/45.5	SPCC	
71	142-128-24	Plain Washer	3	M10	SPC	

PARTS LIST		DEWATERING PUMP			11/8/2019	
ITEM	PART No.	DESCRIPTION	QTY	SIZE	MATERIAL	NOTES
72	141-006-77	Hex.Nut	3	M10	S45C	
	173-003-33	Packing O-Ring Set	1Set	(Marked by *)		
12	122-121-12	O-Ring (S.Box)	1	G-50(49.4xd3.1)	NBR	*
20	121-001-48	Packing (Hose Coupling)	1	KTZ-3.7/7.5(Angle)	NBR	*
25	122-276-13	O-Ring (M.Bracket/M.Frame)	1	160xd3.1	NBR	*
32	122-367-12	O-Ring (Upp. Bearing)	1	52xd3.1	NBR	*
37	121-506-12	Packing (Water Way, Upp.)	1	KTZ23.7/33.7/43.7	NBR	*
41	121-247-12	Packing (Oil Plug)	1	d12.3xd18x2t	PE	*
46	122-133-17	O-Ring (M.Frame/Brg.Housing)	1	G-110(109.4xd3.1)	NBR	*
55	122-283-13	O-Ring (M.Frame/P.Casing)	1	165xd3.1	NBR	*
56	121-124-12	Packing (Water Way, Low.)	1	KTV-37/55	NBR	*
		Lubricant		Turbine Oil VG32 1,250ml		
	183-008-11	Impeller Puller	1	A No.3 1"	FC	

PARTS LIST		DEWATERING PUMP			11/8/2019	
ITEM	PART No.	DESCRIPTION	QTY	SIZE	MATERIAL	NOTES

EXPLODED VIEW

KTZ33.7-63

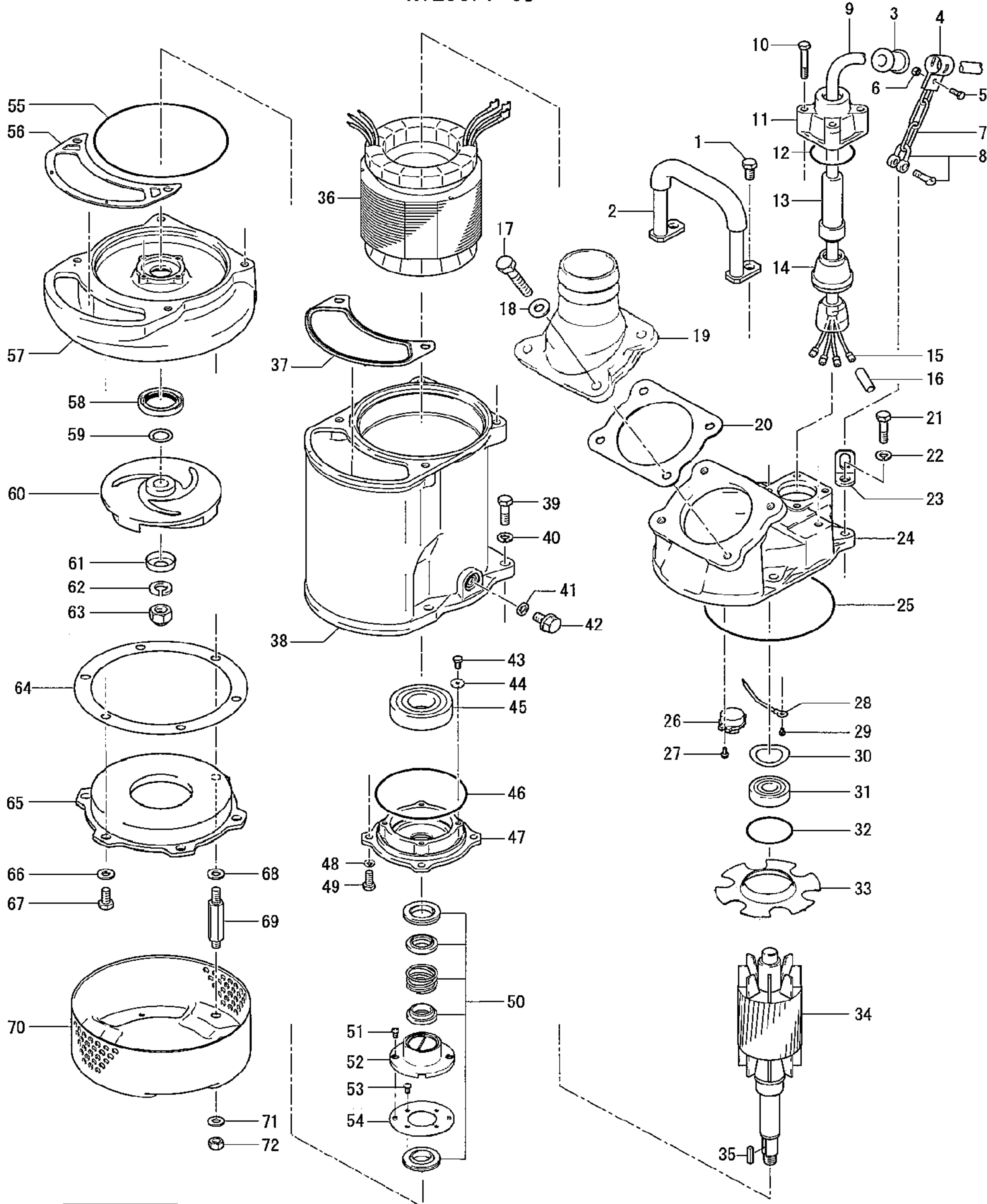

C-01552-1