

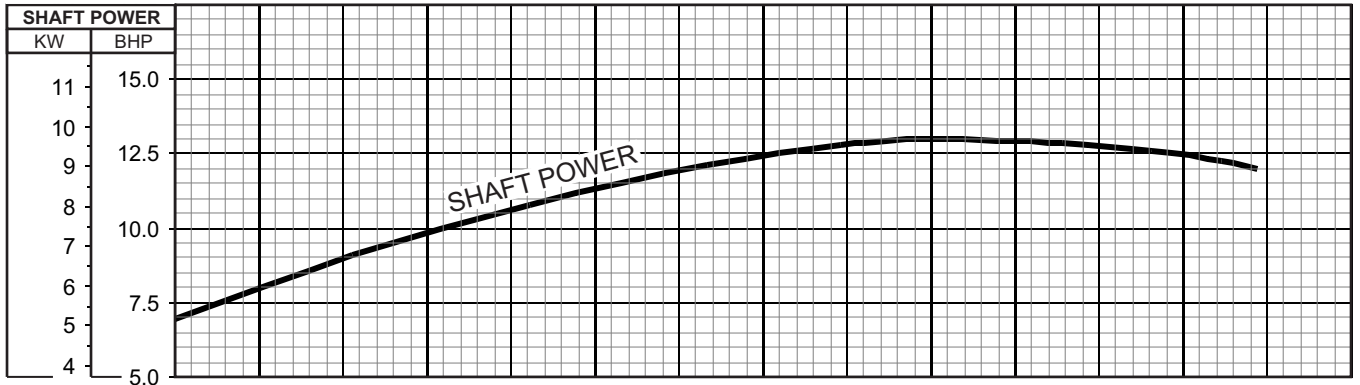

KTZ - SERIES DEWATERING PUMPS

PERFORMANCE CURVE

MODEL	BORE	HP	KW	RPM	SOLIDS DIA	LIQUID	SG.	VISCOSITY	TEMP.
KTZ611-63	4"/100mm	15	11	3520	0.787"/20mm	Water	1.0	1.123 cSt.	60°F
PUMP TYPE	PHASE	VOLTAGE	AMPERAGE		HZ	STARTING METHOD	INS. CLASS		
Dewatering Pump	3	208-230/460/575	39.8-37.4 / 18.6 / 14.9		60	Direct On Line	F		
CURVE No.	DATE	PHASE	VOLTAGE	AMPERAGE	HZ	STARTING METHOD	INS. CLASS		
-	-	-	-	-	-	-	-		

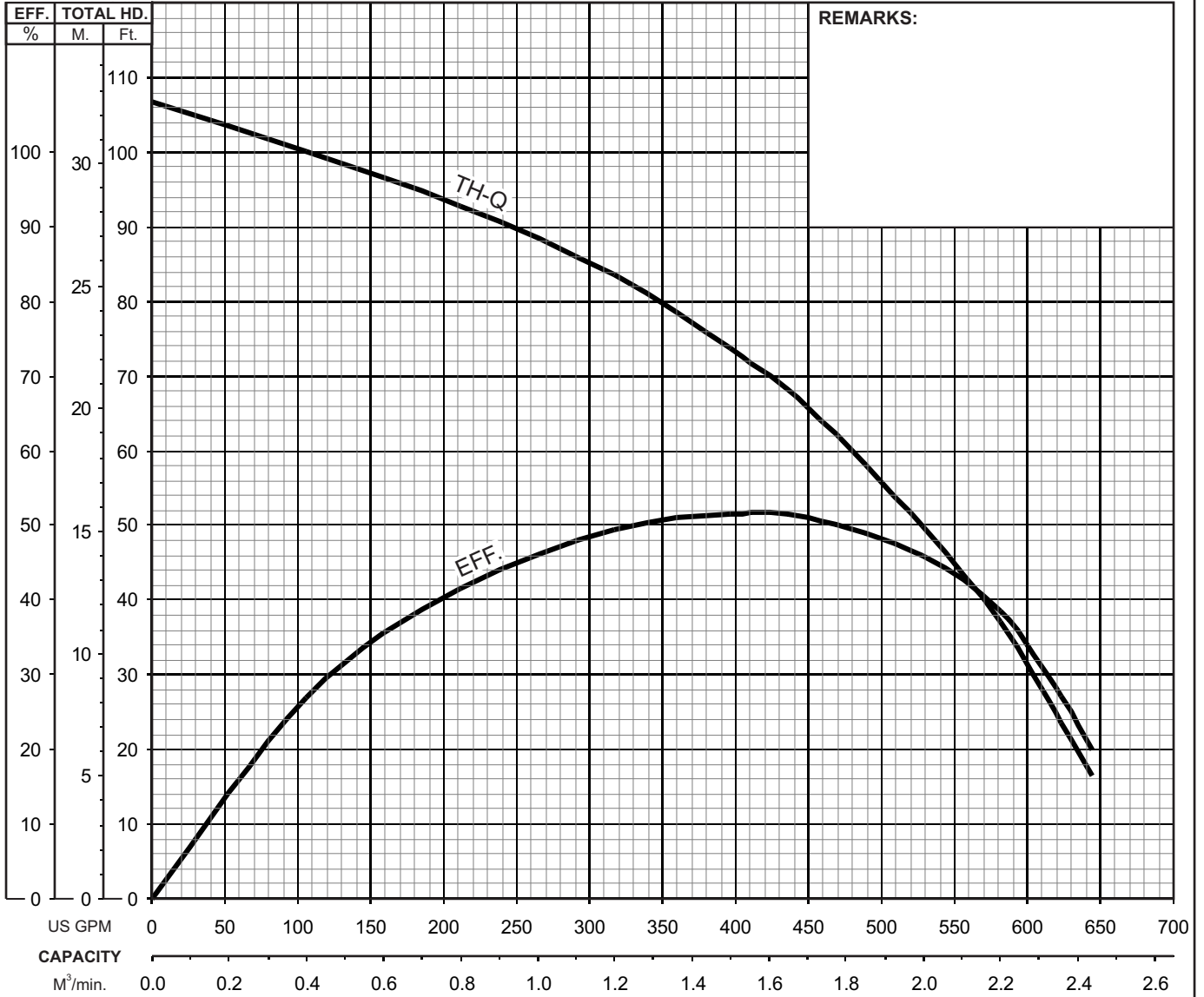



**KTZ SERIES
DEWATERING PUMPS**

DIMENSIONS

**KTZ611-63
KTZ615-61**

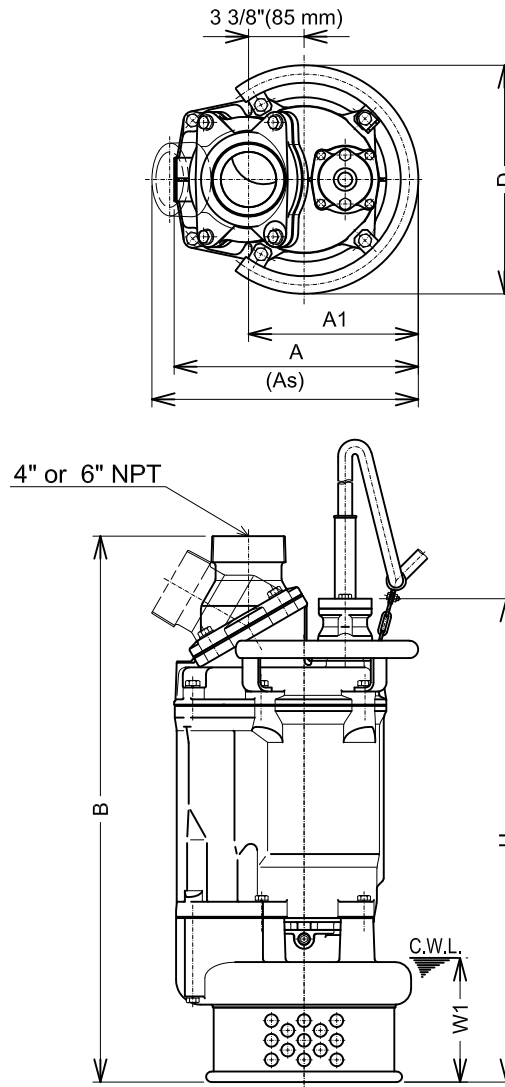

C.W.L. :Continuous running Water Level

DIMENSIONS:USCS (Inch)

Model	HP	NOM. SIZE	Pump & Motor						C.W.L. W1	Wt.* (lbs.)
			A	A1	As	B	D	H		
KTZ611-63(4")	15	4"	14 12/16	10 1/4	16 1/16	32 15/16	13 3/4	29 1/8	7 1/2	291
KTZ611-63	15	*6"	14 12/16	10 1/4	17 1/4	33 11/16	13 3/4	29 1/8	7 1/2	293
KTZ615-61(4")	20	4"	14 12/16	10 1/4	16 1/16	35 11/16	13 3/4	31 7/8	7 1/2	319
KTZ615-61	20	*6"	14 12/16	10 1/4	17 1/4	36 7/16	13 3/4	31 7/8	7 1/2	322

DIMENSIONS:METRIC (mm)

*Excluding Cable

Model	kW	NOM. SIZE	Pump & Motor						C.W.L. W1	Wt.* (kg)
			A	A1	As	B	D	H		
KTZ611-63(4")	11	100	374	260	408	836	350	740	190	132
KTZ611-63	11	*150	374	260	438	856	350	740	190	133
KTZ615-61(4")	15	100	374	260	408	906	350	810	190	145
KTZ615-61	15	*150	374	260	438	926	350	810	190	146

*6" (150mm) is optional



**KTZ - SERIES
DEWATERING PUMPS**

SECTIONAL VIEW

**KTZ411-63
KTZ611-63**

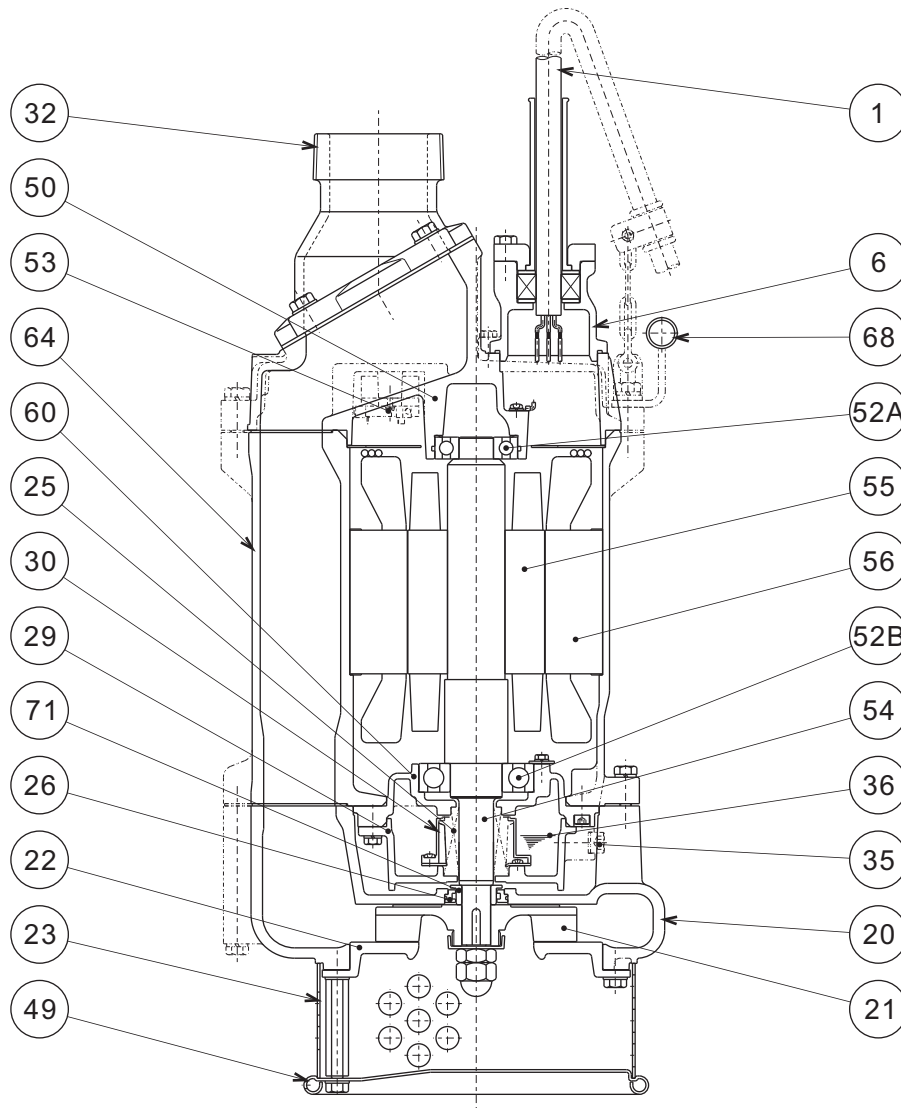

ITEM#	DESCRIPTION	MAIN MATERIAL / NOTE	RELATED ASTM, AISI CODE	RELATED EN CODE	Q'TY
1	Power Cable	Chloroprene Sheath AWG8/4-50ft			1
6	Stuffing Box	Cast Iron	A48M Class30B	EN 1561 GJL-200	1
20	Pump Casing	Cast Iron	A48M Class30B	EN 1561 GJL-200	1
21	Impeller	High Chrome Cast Iron	A532 Class III Type A	DIN 1695 G-X260Cr27	1
22	Suction Cover	Ductile Cast Iron	A536 80-55-06	EN 1563 GJS-500-7	1
23	Suction Strainer	Steel (Cold Rolled)	A109/A1008	EN 10130	1
25	Mechanical Seal	Silicon Carbide / H-30T			1
30	Oil Lifter	PBT Resin			1
26	Labyrinth Ring	Stainless Steel	S 30400	1.4301	1
32	Discharge Connection	Cast Iron / NPT 4" (or 6")	A48M Class30B	EN 1561 GJL-200	1
35	Oil Plug	Stainless Steel	S 30400	1.4301	1
36	Lubricant	Turbine Oil ISO VG32 or SAE10W-20			
49	Bottom Plate	Steel (Cold Rolled)	A109/A1008	EN 10130	1
50	Motor Head Cover	Cast Iron	A48M Class30B	EN 1561 GJL-200	1
52A	Upper Bearing	#6306ZXC3			1
52B	Lower Bearing	#6309ZXC3			1
53	Motor Protector				1
54	Shaft	Stainless Steel	S 42000	1.4028	1
55	Rotor				1
56	Stator				1
60	Bearing Housing	Cast Iron	A48M Class25B	EN 1561 GJL-150	1
64	Motor Housing	Cast Iron	A48M Class30B or 25B	EN 1561 GJL-200 or GJL-150	1
68	Handle	Carbon Steel Pipe + Steel	A53 Type F + A283 Grade D	DIN 1615 St33 + EN 10025 S275	1
71	Shaft Sleeve	Stainless Steel	S 40300	1.4000	1

PARTS LIST		HI-HEAD DEWATERING PUMP			6/7/2018	
ITEM	PART No.	DESCRIPTION	QTY	SIZE	MATERIAL	NOTES
1	140-101-12	Hex.Bolt	6	M12x50	SUS304	
2	142-165-10	Spring Washer	6	M12	SUS304	
3	070-117-11	L-Shape Fitting	1	40x25x4.5t d13Hole	SPC	
4	068-000-32	Handle	1	SM1-2-11-KTZ	SGP+SS	
5	001-844-36	Cabtyre Cable Set (50') 60Hz (USA)	1	4Cx8AWGx50'	GHZ	
6	010-122-10	Cable Clip Rubber	1	No.2	NBR	
7	010-120-18	Cable Clip	1	No.2-1	SPC	
8	141-004-59	Hex.Nut	1	M6	SWRM	
9	140-032-37	Hex.Bolt	1	M6x15	SWRM	
10	095-131-18	Chain	1	4mm(3L)	SS	
11	011-101-19	Shackle	1	6mm(M8,SC)	SS	
12	140-076-17	Hex.Bolt	2	M10x30	SUS304	included in item #5 Cable Ass'y
13	003-183-23	Gland	1	GHZ-311W	FC	included in item #5 Cable Ass'y
14	002-103-26	Cable Protection Tube	1	No.3	NR	included in item #5 Cable Ass'y
15	005-122-17	Bush Washer	2	d23xd53.5x3.2t	SPC	included in item #5 Cable Ass'y
16	004-129-11	Cable Bush	1	d22.5xd54x25l	NBR	included in item #5 Cable Ass'y
17	140-055-10	Hex.Bolt	4	M8x25	SUS304	
18	006-160-10	Stuffing Box	1	GHZ-311W	FC	included in item #5 Cable Ass'y
19	122-128-19	O-Ring	1	G-85(84.4xd3.1)	NBR	*
20	009-129-16	Terminal	4	E (Small)	CU	included in item #5 Cable Ass'y
21	009-101-12	Terminal(C/W Screw)	4	d12x(d6.6xd6.6)x25l	C3604	
22	009-129-16	Terminal	4	E (Small)	CU	
23	002-135-14	Heat Shrink Tube (40°)	m	A(d15x0.3t)	(Vm)	
24	002-132-11	Heat Shrink Tube (40°)	m	A4(d17x0.27t)	(Vm)	
25	140-099-16	Hex.Bolt	4	M12x40	SUS304	
26	142-129-25	Plain Washer	4	M12	SPC	
27	032-001-00	Hose Coupling 4" NPT	1	NPT-4", Angle	FC	
27	032-001-03	Hose Coupling 6" NPT	1	NPT-6", Angle	FC	option
28	121-001-49	Packing	1	KTZ-11kW(Angle)	NBR	*
29	143-164-25	Pan Screw (w/Spring Washer)	1	M6x8	C3604	
30	009-296-15	Earth Terminal	1Set	8mm2x180L		
31	050-001-13	Motor Bracket	1		FC	
32	122-173-19	O-Ring	1	V-225(222.5xd6)	NBR	*
33	053-000-04	Motor Protector 208230V-60Hz	1	KA315-JTXL00	(B.C)	
33	053-000-24	Motor Protector 460V-60Hz	1	KA315-JKZL00	(B.C)	
33	053-000-25	Motor Protector 575V	1	KA315-JKVL00	(B.C)	
34	143-125-24	Pan Screw (w/Spring Washer/Plain Washer)	2	M4x14	SWRM	
35	142-198-12	Wave Washer	1	6306	SK5	
36	052-109-14	Bearing	1	6306ZZC3		
37	122-245-13	O-Ring	1	71.4xd3.1	NBR	*
38	058-000-36	Lead Wire Protection Plate	1	d96xd224.5x1.6t	PE	
39	055-002-61	Rotor	1Set			

PARTS LIST		HI-HEAD DEWATERING PUMP			6/7/2018	
ITEM	PART No.	DESCRIPTION	QTY	SIZE	MATERIAL	NOTES
40	147-139-10	Impeller Key	1	7x7x28l	SUS420	
41	056-007-27	Stator 208230V-60Hz	1Set			
41	056-007-37	Stator 460V-60Hz	1Set			
41	056-007-39	Stator 575V	1Set			
42	121-504-10	Packing (Water Way, Upp.)	1	KTZ411/611	NBR	*
43	064-001-32	Motor Frame	1		FC	
44	140-080-14	Hex.Bolt	4	M10x45	SUS304	
45	142-164-19	Spring Washer	4	M10	SUS304	
46	140-000-06	Hex.Bolt (w/Spring Washer/Plain Washer)	4	M6x12	SWCH	
47	052-112-10	Bearing	1	6309ZZC3		
48	122-285-15	O-Ring	1	155xd3.1	NBR	*
49	060-001-39	Bearing Housing	1		FC	
50	140-269-19	Hex.Socket Cap Bolt	4	M8x25	SUS304	
51	025-000-73	Mechanical Seal	1	H-30T(T) RoHS	SIC	supercedes 025-000-50
52	143-070-23	Pan Screw	2	M5x6	SWRM	
53	030-142-11	Oil Lifter	1	H-30(A)(T)	Resin	
54	143-070-10	Pan Screw	6	M5x6	SWRM	
55	030-147-16	Seal Stopper	1	HT-3035	SPCC	
56	122-285-15	O-Ring	1	155xd3.1	NBR	*
57	121-503-19	Packing (Water Way, Low.)	1	KTZ411/611	NBR	*
58	029-333-17	Oil Casing	1	KTZ47.5/611	FC	
59	142-163-18	Spring Washer	4	M8	SUS304	
60	140-055-10	Hex.Bolt	4	M8x25	SUS304	
61	121-247-12	Packing	1	d12.3xd18x2t	PE	*
62	035-113-18	Oil Plug	1	M12x14	SUS304	
63	071-198-19	Shaft Sleeve	1	d25xd35x17l	SUS403	
64	020-001-06	Pump Casing	1	KTZ411/611	FC	
65	142-164-19	Spring Washer	2	M10	SUS304	
66	140-449-15	Hex.Bolt	2	M10x140	SUS304	
67	122-360-15	O-Ring	1	46.5xd2.5	NBR	*
68	026-238-12	Labyrinth Ring	1	GHV/GHZ-7.5/11KW	SUS304	
69	040-107-28	Impeller Shim		d25.2xd38x0.3t	SUS304	
70	021-K84-15	Impeller (50Hz) OPTION	1	KTZ611-53	HiCrFC	50Hz OPTION
70	02-1K85-16	Impeller (60Hz)	1	KTZ611-63	HiCrFC	
71	047-105-14	Impeller Thread Protect.Cover	1	No.4(22)	SPC	
72	141-009-38	Hex.Nut	1	M20(H=12)	SUS304	
73	141-034-16	Hex.Cap Nut	1	M20	SUS304	
74	120-111-13	Packing (S.Cover)		d221xd268x0.3t	PE	
75	022-000-57	Suction Cover	1	KTZ67.5/611	FCD	
76	142-128-24	Plain Washer	3	M10	SPC	
77	140-075-16	Hex.Bolt	3	M10x25	SUS304	

PARTS LIST		HI-HEAD DEWATERING PUMP			6/7/2018	
ITEM	PART No.	DESCRIPTION	QTY	SIZE	MATERIAL	NOTES
78	142-128-24	Plain Washer	3	M10	SPC	
79	144-000-57	Stud Bolt	3	M10x124(26/14)	SUS403	supercedes 144-119-15 (SUS403)
80	023-252-13	Strainer	1	KTV-75/110	SPCC	
81	049-133-20	Bottom Plate	1	KRS-C3/A3	SPC	
82	142-128-24	Plain Washer	3	M10	SPC	
83	141-006-77	Hex.Nut	3	M10	S45C	
	173-000-86	Packing O-Ring Set	1Set	(Marked by *)		
19	122-128-19	O-Ring (S.Box)	1	G-85(84.4xd3.1)	NBR	*
28	121-001-49	Packing (Hose Coupling)	1	KTZ-11kW(Angle)	NBR	*
32	122-173-19	O-Ring (M.Bracket/M.Frame)	1	V-225(222.5xd6)	NBR	*
37	122-245-13	O-Ring (Upp. Bearing)	1	71.4xd3.1	NBR	*
42	121-504-10	Packing (Water Way, Upp.)	1	KTZ411/611	NBR	*
48	122-285-15	O-Ring (M.Frame/Brg.Housing)	1	155xd3.1	NBR	*
56	122-285-15	O-Ring (Brg.Housing/O.Casing)	1	155xd3.1	NBR	*
57	121-503-19	Packing (Water Way, Low.)	1	KTZ411/611	NBR	*
61	121-247-12	Packing (Oil Plug)	1	d12.3xd18x2t	PE	*
67	122-360-15	O-Ring (Labyrinth Ring)	1	46.5xd2.5	NBR	*
		Lubricant		Turbine Oil VG32 760ml		
	183-009-12	Impeller Puller	1	A No.4 1"1/4"	FC	

PARTS LIST		HI-HEAD DEWATERING PUMP			6/7/2018	
ITEM	PART No.	DESCRIPTION	QTY	SIZE	MATERIAL	NOTES

EXPLODED VIEW

KTZ611-53/63

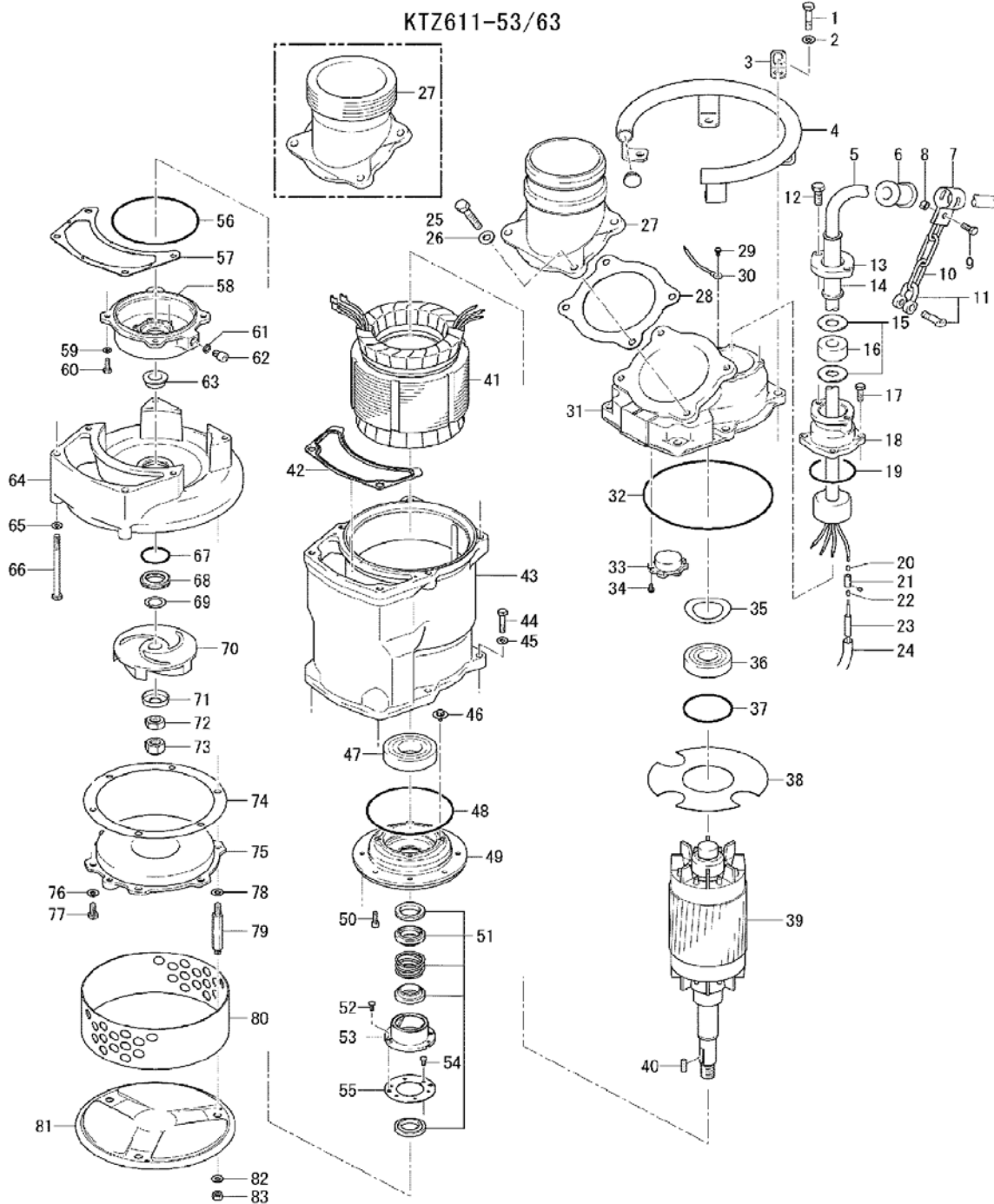

C-01586-1