

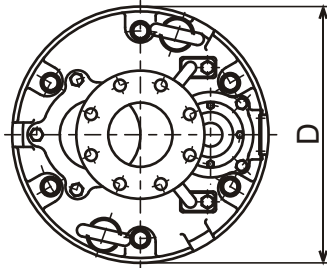

**LH - SERIES
DEWATERING PUMPS**

DIMENSIONS

LH422-61
LH430-61



4" JIS10K (150PSI) Flange
with
4" NPT Companion Flange

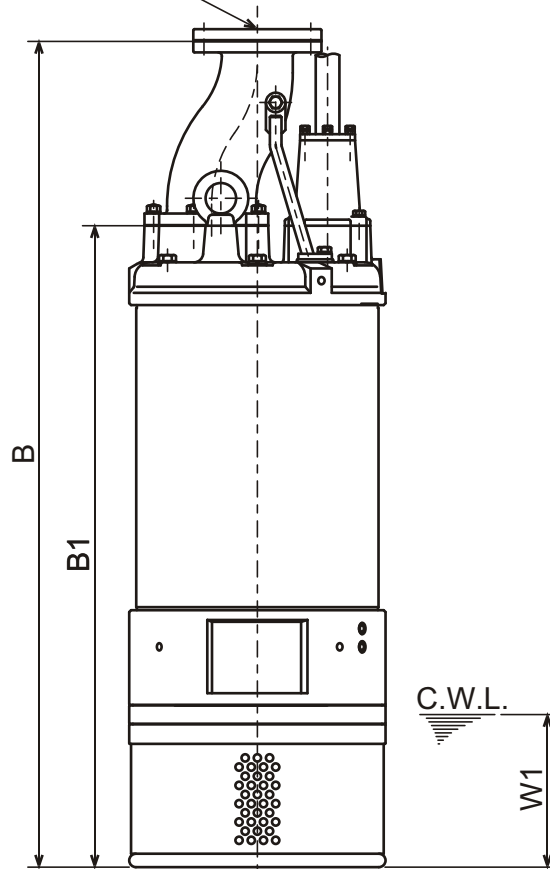

C.W.L. : Continuous running Water Level

DIMENSIONS:USCS (Inch)

Model	HP	NOM. SIZE	Pump & Motor			C.W.L. W1	Wt. (lbs.)
			B	B1	D		
LH422-61	30	4"	53 1/4	41 3/8	16 9/16	9 7/8	770
LH430-61	40	4"	53 1/4	41 3/8	16 9/16	9 7/8	780

DIMENSIONS:METRIC (mm)

Model	kW	NOM. SIZE	Pump & Motor			C.W.L. W1	Wt. (kg)
			B	B1	D		
LH422-61	22	100	1352	1051	420	250	350
LH430-61	30	100	1352	1051	420	250	355



LH - SERIES DEWATERING PUMPS

PERFORMANCE CURVE

MODEL	BORE	HP	KW	RPM	SOLIDS DIA	LIQUID	SG.	VISCOSITY	TEMP.
LH430-61	4"/100mm	40	30	3475	0.236"/6mm	Water	1.0	1.123 CST	60°F
PUMP TYPE	PHASE	VOLTAGE	AMPERAGE	HZ	STARTING METHOD	INS. CLASS			
Dewatering Pump	3	460/575	51.0/38.5	60	Star-Delta	F			
CURVE No.	DATE	PHASE	VOLTAGE	AMPERAGE	HZ	STARTING METHOD	INS. CLASS		
-	-	-	-	-	-	-	-		

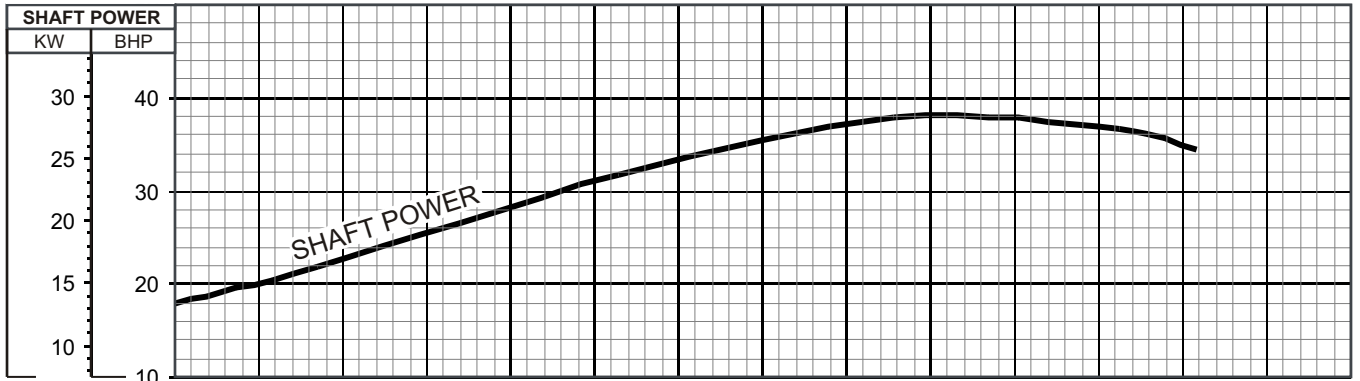
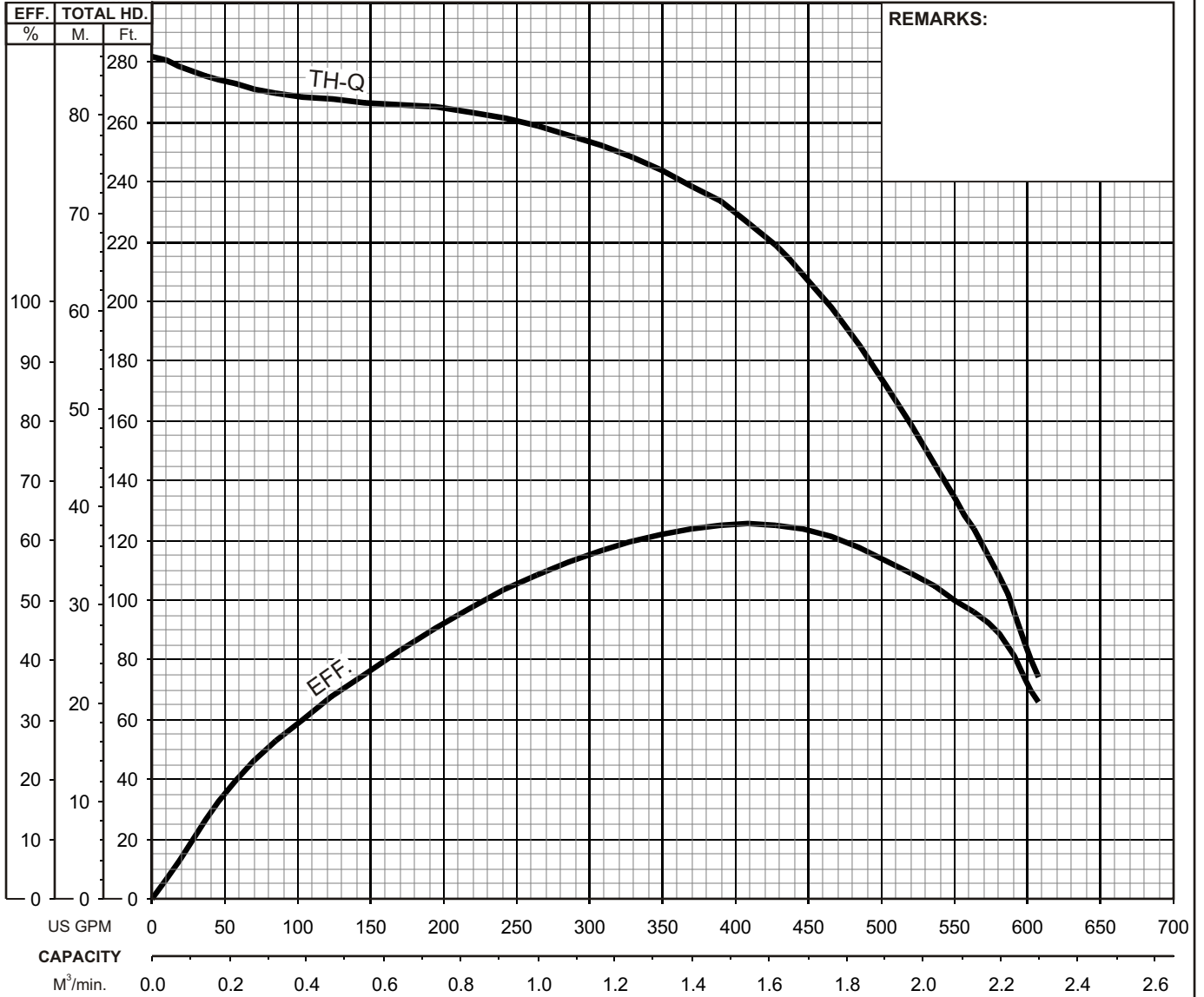



TSURUMI PUMP

**LH - SERIES
DEWATERING PUMPS**

SECTIONAL VIEW

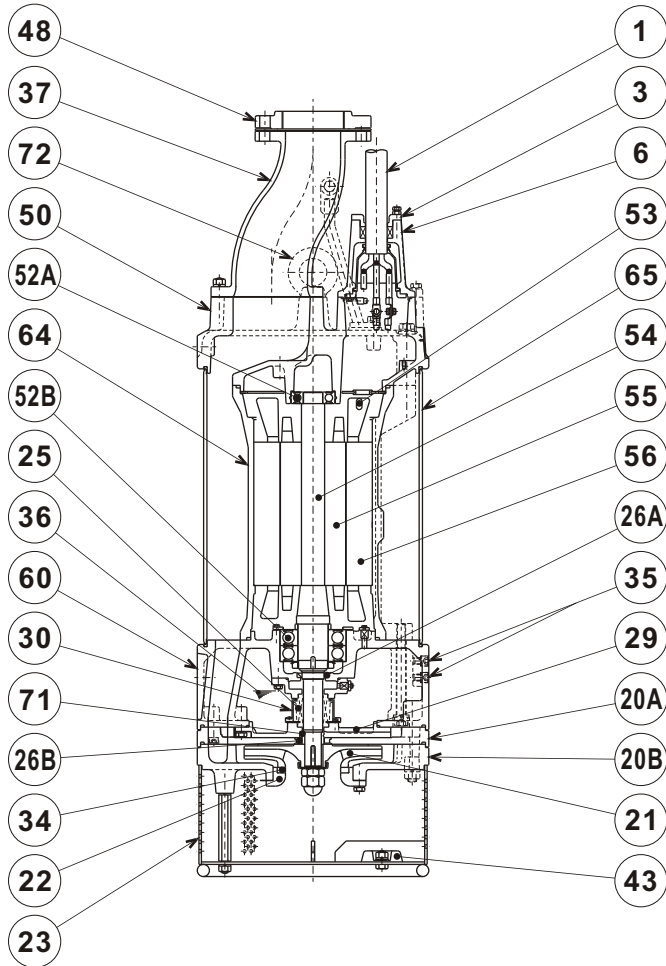

LH430-61

ITEM#	DESCRIPTION	MAIN MATERIAL / NOTE	ASTM, AISI CODE	RELATED EN CODE	Q'TY
1	Power Cable	Chloroprene Sheath AWG 4/6 , 6/1 , 14/2 -50ft			1
3	Gland	Cast Iron	A48M Class30B	EN 1561 GJL-200	1
6	Stuffing Box	Cast Iron	A48M Class30B	EN 1561 GJL-200	1
20A	Upper Pump Casing	Ductile Cast Iron	A536 65-45-12	EN 1563 GJS-450-10	1
20B	Lower Pump Casing	Ductile Cast Iron	A536 65-45-12	EN 1563 GJS-450-10	1
21	Impeller	High Chrome Cast Iron	A532 Class TypeA	DIN 1695 G-X260Cr27	1
22	Suction Cover	Cast Iron	A48M Class30B	EN 1561 GJL-200	1
23	Suction Strainer	Steel	A283 Grade D	EN 10025 S275	1
25	Mechanical Seal	Silicon Carbide / H-35T			1
26A	Oil Seal	NBR / SC-40588			1
26B	Labyrinth Ring	Stainless Steel	S 30400	1.4301	1
29	Oil Casing	Cast Iron	A48M Class30B	EN 1561 GJL-200	1
30	Oil Lifter	PBT Resin W/GF40			1
34	Mouth Ring	High Chrome Cast Iron	A532 Class TypeA	DIN 1695 G-X260Cr27	1
35	Oil Plug	Stainless Steel	S 30400	1.4301	2
36	Lubricant	Turbine Oil ISO VG32 or SAE 10W-20			
37	Discharge Pipe	Ductile Cast Iro / 4" JIS10K	A536 65-45-12	EN 1563 GJS-450-10	1
43	Cathodic Protection Plate	Aluminium Alloy			4
48	Companion Flange	Cast Iron / NPT 4" JIS10K	A48M Class30B	EN 1561 GJL-200	1
50	Motor Bracket	Cast Iron	A48M Class30B	EN 1561 GJL-200	1
52A	Upper Bearing	#6307ZZC3			1
52B	Lower Bearing	#6311ZZD2C3			1
53	Motor Protector				3
54	Shaft	Stainless Steel	S 42000	1.4028	1
55	Rotor				1
56	Stator				1
60	Bearing Housing	Cast Iron	A48M Class30B	EN 1561 GJL-200	1
64	Motor Housing	Cast Iron	A48M Class30B	EN 1561 GJL-200	1
65	Outer Cover	Steel	A283 Grade D	EN 10025 S275	1
71	Shaft Sleeve	Stainless Steel	S 40300	1.4000	1
72	Lifting Lug Bolt	Stainless Steel	S 30400	1.4301	2

PARTS LIST		HI PRESSURE DEWATERING PUMP			1/16/2015	
ITEM	PART No.	DESCRIPTION	QTY	SIZE	MATERIAL	NOTES
1	141-006-19	Hex.Nut	3	M10	SUS304	
2	010-103-21	Cable Clip	2	No.4	SPC	
3	140-074-15	Hex.Bolt	3	M10x20	SUS304	
4	009-117-11	Terminal	6	R-22-6	CU	included in ITEM #7 Cable Assembly
5	009-107-18	Terminal	1	R-14-6	CU	included in ITEM #7 Cable Assembly
6	009-116-10	Terminal	2	R-2-4	CU	included in ITEM #7 Cable Assembly
7	001-007-70	Cabtyre Cable Set (50') 460-575V-60Hz	1	2PNCTFMulti-core 9Cx22mm2	(Vm)	
8	011-110-11	Shackle	1	6mm(M8,SC)	SS	
9	095-132-19	Chain	1	4mm(6L)	SS	
10	072-103-23	Eve Bolt	2	M24	SUS304	
11	140-056-53	Hex.Bolt	4	M8x30	SUS304	included in ITEM #7 Cable Assembly
12			4	M8	SUS304	included in ITEM #7 Cable Assembly
13	003-106-19	Gland	1	No.5	FC	included in ITEM #7 Cable Assembly
14	004-170-17	Cable Bush	1	d39.5xd58.5x22l	CR	included in ITEM #7 Cable Assembly
15	005-106-28	Bush Washer	1	d42xd57x3.2t	SPC	included in ITEM #7 Cable Assembly
16	140-076-17	Hex.Bolt	4	M10x30	SUS304	
17	142-164-19	Spring Washer	4	M10	SUS304	
18	006-119-27	Stuffing Box	1	KRS-8L	FC	included in ITEM #7 Cable Assembly
19	122-135-19	O-Ring	1	G-120(119.4xd3.1)	NBR	*
20	008-132-19	Mould Cover	1	KRS-819/822(L)	NBR	included in ITEM #7 Cable Assembly
21	003-149-14	Gland (Lower)	1	No.5	FC	included in ITEM #7 Cable Assembly
22	141-004-59	Hex.Nut	6	M6	SWRM	
23	009-168-17	Terminal	6	R-22-S6	CU	included in ITEM #7 Cable Assembly
24	009-107-18	Terminal	6	R-14-6	CU	
25	140-029-28	Hex.Bolt	6	M6x10	SWRM	
26	002-115-18	Heat Shrink Tube (Sold per meter)	m	EVA(d16.5x1t)	(Vm)	
27	002-116-19	Heat Shrink Tube (Sold per meter)	m	A4(d20x0.35t)	(Vm)	
28	009-107-18	Terminal	1	R-14-6	CU	included in ITEM #7 Cable Assembly
29	143-041-12	Pan Screw	1	M6x8	SWRM	
30	009-114-18	Connector	2	PC-4020M		included in ITEM #7 Cable Assembly
31	009-115-19	Connector	2	PC-4020F		
32	037-429-16	Center-Flange Discharge Pipe	1	LH422/430-51/61	FCD	
33	141-007-10	Hex.Nut	5	M12	SUS304	
34	142-165-10	Spring Washer	5	M12	SUS304	
35	121-374-19	Packing	1	d140xd172x1t	THREE SHEET	*
36	144-000-46	Stud Bolt	5	M12x64(24/27)	SUS304	
37	140-098-15	Hex.Bolt	2	M12x35	SUS304	
38	142-165-10	Spring Washer	2	M12	SUS304	
39						
40	127-287-12	Stay 2	1	LH422/430-51/61For (Left)	SS	
41	127-286-11	Stay 1	1	LH422/430-51/61For (Right)	SS	
42	140-097-14	Hex.Bolt	2	M12x30	SUS304	
43	142-165-10	Spring Washer	2	M12	SUS304	
44	140-138-18	Hex.Bolt	6	M16x130	SUS304	

* Indicates items included in set

PARTS LIST		HI PRESSURE DEWATERING PUMP			1/16/2015	
ITEM	PART No.	DESCRIPTION	QTY	SIZE	MATERIAL	NOTES
45	142-166-11	Spring Washer	6	M16	SUS304	
46	142-353-17	Seal Washer	6	SM-16	SUS+NBR	*
47	050-495-14	Motor Bracket	1		FC	
48	144-584-15	Hex. Socket Cap Screw	4	M12x16	SUS304	
49	122-157-17	O-Ring	1	G-260(259.3xd5.7)	NBR	*
50	121-593-16	Packing	1	LH619/422/430(L)	NBR	*
51	058-203-17	Lead Wire Protection Plate	1	d108xd269x3.2t	SPHC	
52	122-127-18	O-Ring	1	G-80(79.4xd3.1)	NBR	*
53	142-199-13	Wave Washer	1	6208/6307	SK5	
54	052-110-18	Bearing	1	6307ZZC3		
55	065-387-18	Outer Cover	1		SS	
56	121-593-16	Packing	1	LH619/422/430(L)	NBR	*
57	053-309-19	Motor Protector	3	9700K-46-215	(H)	
58		Stator 460V-60Hz	1Set			
59		Stator 575V-60Hz	1Set			
59	064-572-19	Motor Frame	1		FC	
60	122-259-10	O-Ring	1	12xd3	NBR	*
61	144-490-13	Stator Set Bolt	1	M12(B=21)	SUS403	
62	122-153-13	O-Ring	1	G-220(219.3xd5.7)	NBR	*
63	055-888-13	Rotor	1Set			
64	147-064-13	Impeller Key	1	7x7x37.5l	SUS420	
65	140-033-25	Hex.Bolt	3	M6x16	SWRM	
66	062-177-14	Bearing Fixing Plate	1		SS	
67	052-142-19	Bearing	1Set	6311ZZD2C3		
68	142-244-14	Bearing Washer	1	AW11	SPCC	
69	141-076-10	Bearing Nut	1	AN11	SS	
70	026-271-17	Oil Seal	1	SC-40588	NBR	
71	140-016-19	Hex.Bolt	2	M5x12	SUS304	
72	003-219-16	Gland	1		SPHC	
73	032-423-15	Bush	1	d9.5x18.5L	NBR	
74	121-247-12	Packing	2	d12.3xd18x2t	PE	*
75	035-113-18	Oil Plug	2	M12x14	SUS304	
76	144-584-15	Hex. Socket Cap Screw	4	M12x16	SUS304	
77	060-491-11	Bearing Housing	1		FC	
78	122-258-19	O-Ring	1	395xd5	NBR	*
79	142-166-11	Spring Washer	4	M16	SUS304	
80	140-518-16	Hex.Socket Cap Bolt	4	M16x170	SUS304	
81	122-129-10	O-Ring	1	G-90(89.4xd3.1)	NBR	*
82	028-170-11	Seal Housing	1	LH619/422/622/430-51/61	FC	
83	142-163-18	Spring Washer	4	M8	SUS304	
84	140-055-10	Hex.Bolt	4	M8x25	SUS304	
85	032-423-15	Bush	1	d9.5x18.5L	NBR	
86	003-219-16	Gland	1		SPHC	
87	140-016-19	Hex.Bolt	2	M5x12	SUS304	

* Indicates items included in set

PARTS LIST		HI PRESSURE DEWATERING PUMP			1/16/2015	
ITEM	PART No.	DESCRIPTION	QTY	SIZE	MATERIAL	NOTES
88	144-444-25	Stud Bolt	4	M16x100(38/24)(JIS)	SUS304	
89	025-257-14	Mechanical Seal	1	H-35T	SiC	
90	143-070-23	Pan Screw	2	M5x6	SWRM	
91	030-156-18	Oil Lifter	1	H-35(A)(T)	Resin	
92	143-070-10	Pan Screw	3	M5x6	SWRM	
93	030-150-12	Seal Stopper	1	H-35(A)(T)	SPCC	
94	122-250-11	O-Ring	1	230xd3.8	NBR	*
95	029-398-10	Oil Casing	1	LH619/422/622/430-51/61	FC	
96	142-164-19	Spring Washer	4	M10	SUS304	
97	140-076-17	Hex.Bolt	4	M10x30	SUS304	
98	020-000-33	Upper Pump Casing (w/Labyrinth Ring)	1	LH619/422/622/430-51/61	FCD	
99	140-289-15	Hex.Socket Cap Bolt	4	M10x40	SUS304	
100	122-258-19	O-Ring	1	395xd5	NBR	*
101	040-125-19	Impeller Shim		d31xd45.2x0.5t	SUS304	
102	071-000-03	Shaft Sleeve	1	LH619/422/622/430-51/61	SUS403	
103	021R2019	Impeller (60Hz)	1	LH430-61	HiCrFC	
104	047-106-28	Impeller Thread Protect.Cover	1	No.5(26)	SUS304	
105	141-011-20	Hex.Nut	2	M24(H=14)	SUS304	
106	141-035-17	Hex.Cap Nut	1	M24	SUS304	
107	020B7411	Pump Casing (Lower)	1	LH422/430-51/61	FCD	
108	142-166-11	Spring Washer	4	M16	SUS304	
109	141-008-11	Hex.Nut	4	M16	SUS304	
110	142-165-10	Spring Washer	4	M12	SUS304	
111	144-573-11	Stud Bolt	4	M12x164(22/22)	SUS403	
112	120-175-15	Packing (S.Cover)		LH615/422/430-51/61	PE	*
113	022-000-09	Suction Cover (w/Mouth Ring)	1	LH615/422/430-51/61	FC	
114	142-164-19	Spring Washer	4	M10	SUS304	
115	140-075-16	Hex.Bolt	4	M10x25	SUS304	
116	023-001-29	Strainer Stand	1	LH422/430-51/61	SS	
117	142-165-10	Spring Washer	4	M12	SUS304	
118	141-007-10	Hex.Nut	4	M12	SUS304	
119	141-007-10	Hex.Nut	4	M12	SUS304	
120	142-165-10	Spring Washer	4	M12	SUS304	
121	142-129-12	Plain Washer	4	M12	SUS304	
122	043-102-19	Cathodic Protection Plate	4	AB-1HS(75x70x20t)	Al	
123	140-096-13	Hex.Bolt	4	M12x25	SUS304	
		NPT Flange Version				
	048-139-10	Screwed Flange	1	NPT-4(JIS10K)	FC	
	121-106-34	Packing	1	JIS10Kx100mm	NR	
	140-130-10	Hex.Bolt	8	M16x70	SUS304	
	141-008-11	Hex.Nut	8	M16	SUS304	
	142-166-11	Spring Washer	8	M16	SUS304	
	173-000-21	Packing O-Ring Set	1Set	(Marked by *)		
19	122-135-19	O-Ring (S.Box)	1	G-120(119.4xd3.1)	NBR	*

* Indicates items included in set

PARTS LIST		HI PRESSURE DEWATERING PUMP			1/16/2015	
ITEM	PART No.	DESCRIPTION	QTY	SIZE	MATERIAL	NOTES
35	121-374-19	Packing (Discharge Pipe)	1	d140xd172xtt	THREE SHEET	*
46	142-353-17	Seal Washer (Motor Bracket bolt)	6	SM-16	SUS+NBR	*
49	122-157-17	O-Ring (M.Bracket/M.Frame)	1	G-260(259.3xd5.7)	NBR	*
50	121-593-16	Packing (M.Bracket/Out.Cover)	1	LH619/422/430(L)	NBR	*
52	122-127-18	O-Ring (Upp. Bearing)	1	G-80(79.4xd3.1)	NBR	*
56	121-593-16	Packing (Out.Cover/Brq.Housing)	1	LH619/422/430(L)	NBR	*
60	122-259-10	O-Ring (Stator Set Bolt)	1	12xd3	NBR	*
62	122-153-13	O-Ring (M.Frame/Brq.Housing)	1	G-220(219.3xd5.7)	NBR	*
74	121-247-12	Packing (Oil Plug)	2	d12.3xd18x2t	PE	*
78	122-258-19	O-Ring (M.Frame/Brq.Housing)	1	395xd5	NBR	*
81	122-129-10	O-Ring (Brq.Housing/Seal Housing)	1	G-90(89.4xd3.1)	NBR	*
94	122-250-11	O-Ring (Brq.Housing/O.Casing)	1	230xd3.8	NBR	*
100	122-258-19	O-Ring (Upp./Low. P.Casing)	1	395xd5	NBR	*
		Lubricant		Turbine Oil VG32 6.900ml		

PARTS LIST		HI PRESSURE DEWATERING PUMP			1/16/2015	
ITEM	PART No.	DESCRIPTION	QTY	SIZE	MATERIAL	NOTES

EXPLODED VIEW

LH430-51/61

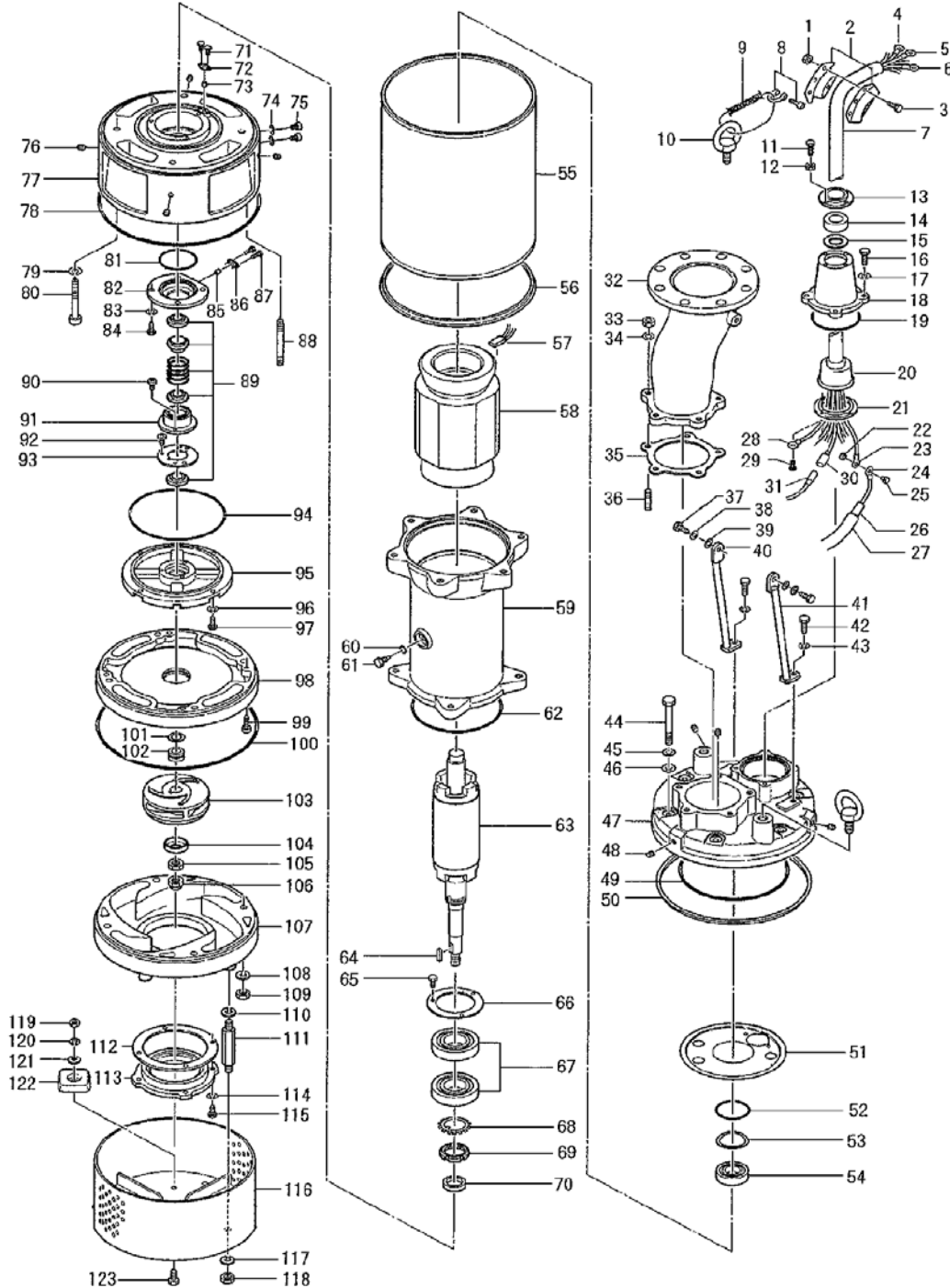

C-00459-1