

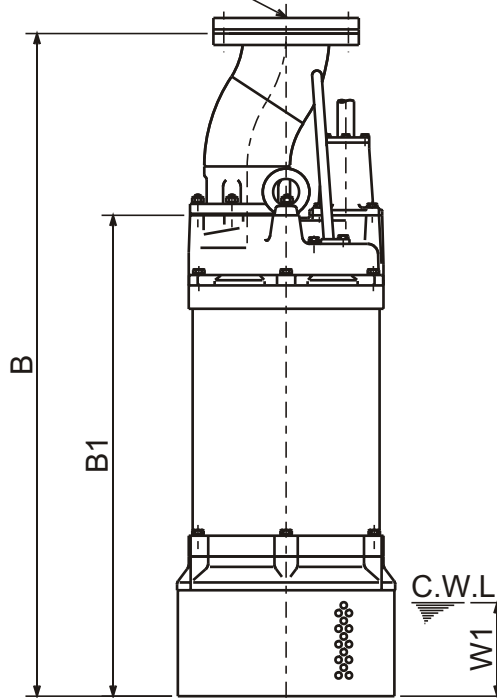

**LH - SERIES
DEWATERING PUMPS**

DIMENSIONS

LH637-60
LH837-60
LH645-60
LH845-60

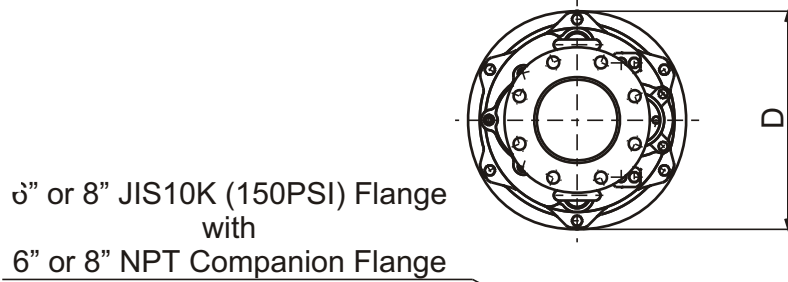

C.W.L. : Continuous running Water Level

DIMENSIONS:USCS (Inch)

Model	HP	NOM. SIZE	Pump & Motor			C.W.L.	Wt. (lbs.)
			B	B1	D	W1	
LH637-60	50	6"	57	40 7/16	20 7/8	7 1/8	1090
LH837-60	50	8"	58 9/16	40 7/16	20 7/8	7 1/8	1090
LH645-60	60	6"	57	40 7/16	20 7/8	7 1/8	1120
LH845-60	60	8"	58 9/16	40 7/16	20 7/8	7 1/8	1120

DIMENSIONS:METRIC (mm)

Model	kW	NOM. SIZE	Pump & Motor			C.W.L.	Wt. (kg)
			B	B1	D	W1	
LH637-60	37	150	1448	1027	530	180	495
LH837-60	37	200	1488	1027	530	180	495
LH645-60	45	150	1448	1027	530	180	510
LH845-60	45	200	1488	1027	530	180	510



LH - SERIES DEWATERING PUMPS

PERFORMANCE CURVE

MODEL	BORE	HP	KW	RPM	SOLIDS DIA	LIQUID	SG.	VISCOSITY	TEMP.
LH845-60	8"/200mm	60	45	3530	0.787"/20mm	Water	1.0	1.123 CST	60°F
PUMP TYPE		PHASE	VOLTAGE	AMPERAGE		HZ	STARTING METHOD		INS. CLASS
Dewatering Pump		3	460 / 575	67.0 / 53.0		60	Star-Delta		F
CURVE No.	DATE	PHASE	VOLTAGE	AMPERAGE		HZ	STARTING METHOD		INS. CLASS
-	-	-	-	-		-	-		-

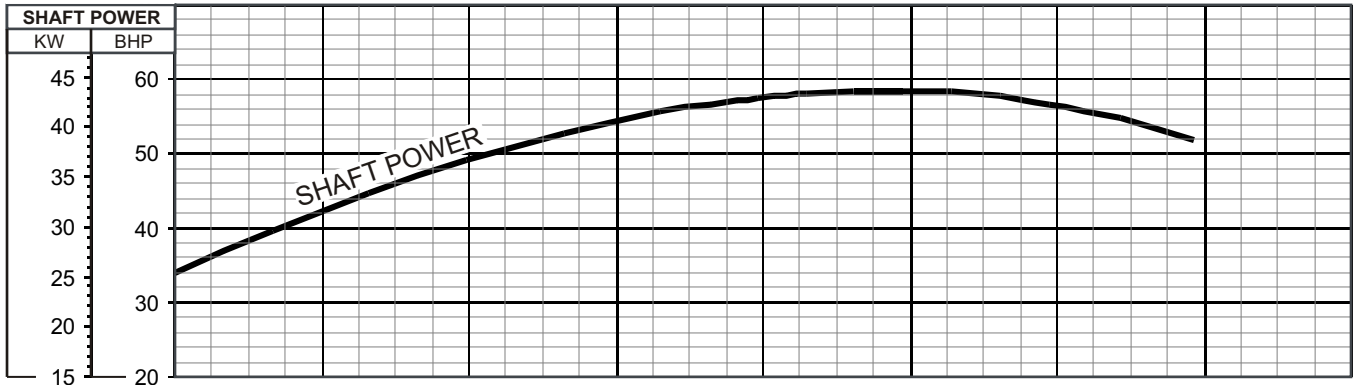
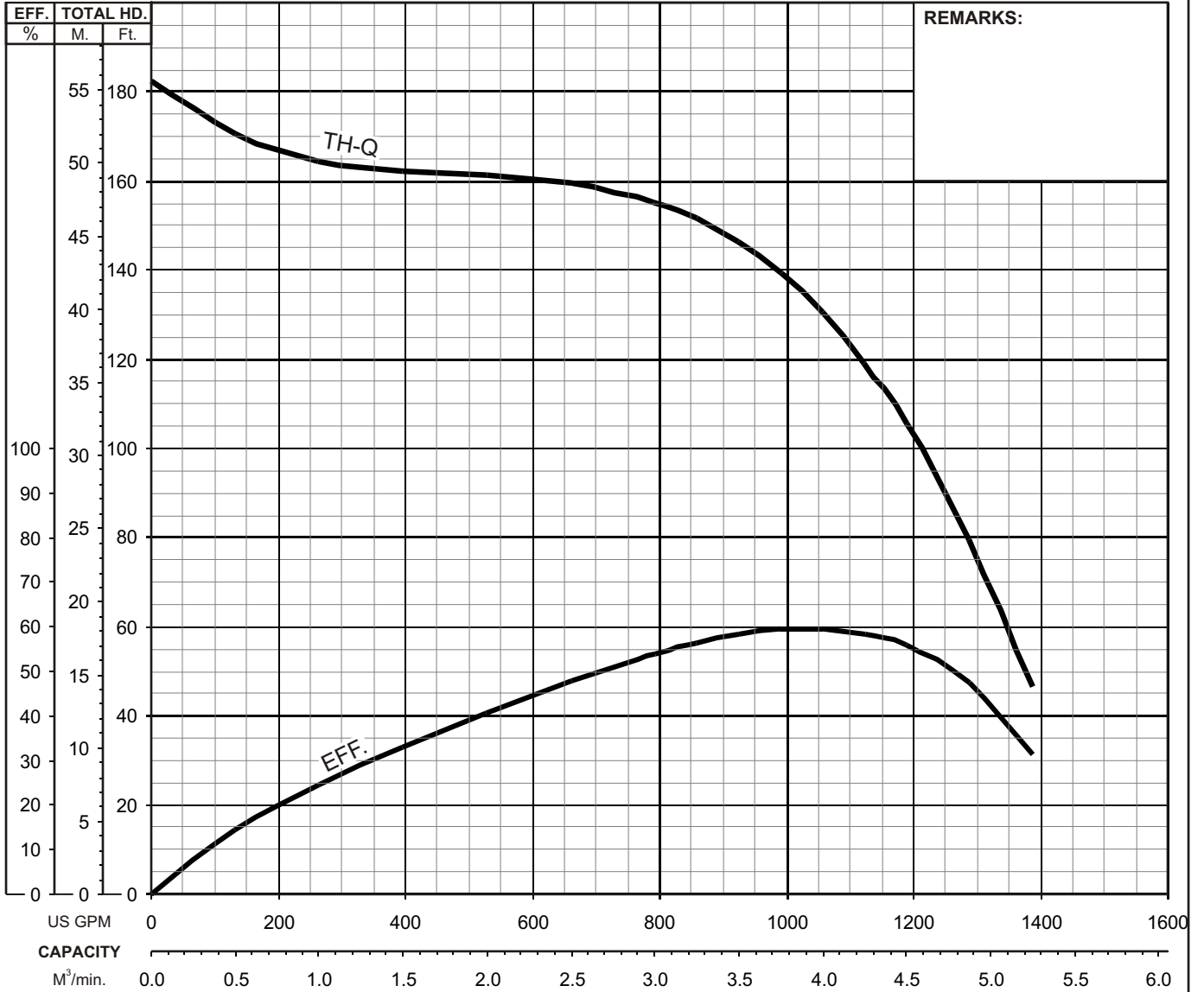



LH - SERIES DEWATERING PUMPS

SECTIONAL VIEW

LH637-60
LH837-60
LH645-60
LH845-60

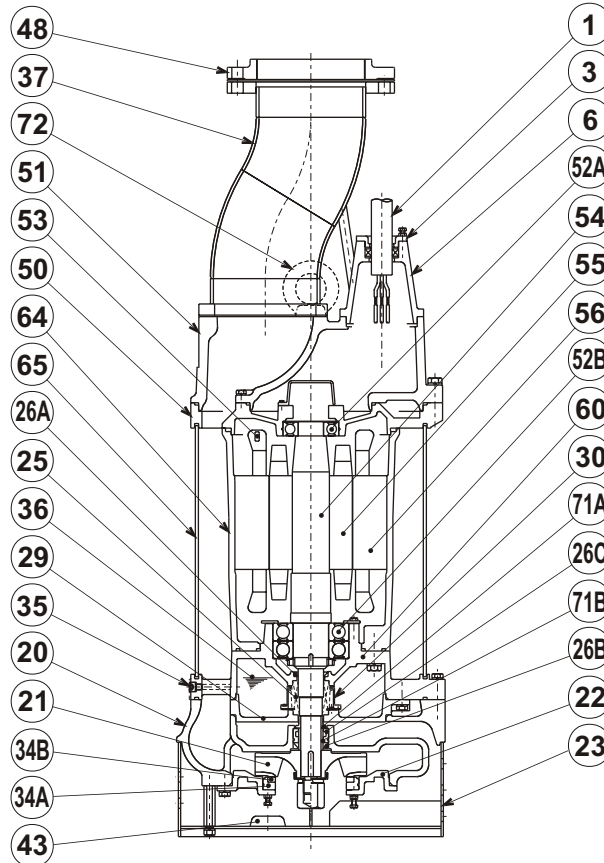

ITEM#	DESCRIPTION	MAIN MATERIAL / NOTE	ASTM, AISI CODE	RELATED EN CODE	Q'TY
1	Power Cable (LH637/837)	Chloroprene Sheath AWG 2/6 , 4/1 , 14/2 -50ft			1
	Power Cable (LH645/845)	Chloroprene Sheath AWG 4/6 , 6/1 , 14/2 -50ft			
3	Gland	Cast Iron	A48M Class30B	EN 1561 GJL-200	1
6	Stuffing Box	Cast Iron	A48M Class30B	EN 1561 GJL-200	1
20	Pump Casing	Cast Iron	A48M Class30B	EN 1561 GJL-200	1
21	Impeller	High Chrome Cast Iron	A532 Class TypeA	DIN 1695 G-X260Cr27	1
22	Suction Cover	Cast Iron	A48M Class30B	EN 1561 GJL-200	1
23	Suction Strainer	Steel	A283 Grade D	EN 10025 S275	1
25	Mechanical Seal	Silicon Carbide / HT-4550N			1
26A	Oil Seal	NBR / SC50689			1
26B	Oil Seal	NBR / TCN487012			1
26C	Labyrinth Ring	Stainless Steel	S 30400	1.4301	1
29	Oil Casing	Cast Iron	A48M Class30B	EN 1561 GJL-200	1
30	Oil Lifter	PBT Resin W/GF40			1
34A	Suction Mouth	Cast Iron	A48M Class30B	EN 1561 GJL-200	1
34B	Mouth Ring	High Chrome Cast Iron	A532 Class TypeA	DIN 1695 G-X260Cr27	1
35	Oil Plug	Stainless Steel	S 30400	1.4301	2
36	Lubricant	Turbine Oil ISO VG32 or SAE 10W-20			
37	Discharge Pipe	Steel Pipe (& Steel) / 6" or 8" JIS10K	A53 Type F (& A283 Grade D)	DIN 1615 St 33 (& EN 10025 S275)	1
43	Cathodic Protection Plate	Aluminium Alloy			3
48	Companion Flange	Cast Iron / NPT 6" or 8" JIS10K	A48M Class30B	EN 1561 GJL-200	1
50	Motor Bracket	Cast Iron	A48M Class30B	EN 1561 GJL-200	1
51	Head Cover	Cast Iron	A48M Class30B	EN 1561 GJL-200	1
52A	Upper Bearing	#6310ZZC3			1
52B	Lower Bearing	#6314ZZD2C3			1
53	Motor Protector				3
54	Shaft	Stainless Steel	S 42000	1.4028	1
55	Rotor				1
56	Stator				1
60	Bearing Housing	Cast Iron	A48M Class30B	EN 1561 GJL-200	1
64	Motor Housing	Cast Iron	A48M Class30B	EN 1561 GJL-200	1
65	Outer Cover	Steel	A283 Grade D	EN 10025 S275	1
71A	Shaft Sleeve (Upper)	Stainless Steel	S 40300	1.4000	1
71B	Shaft Sleeve (Lower)	Stainless Steel	S 40300	1.4000	1
72	Lifting Lug Bolt	Steel	A283 Grade D	EN 10025 S275	2

PARTS LIST		HI PRESSURE DEWATERING PUMP			1/30/2018	
ITEM	PART No.	DESCRIPTION	QTY	SIZE	MATERIAL	NOTES
1	010-103-21	Cable Clip	2	No.4	SPC	
2	141-006-19	Hex.Nut	3	M10	SUS304	
3	140-074-15	Hex.Bolt	3	M10x20	SUS304	
4	009-117-11	Terminal	6	R-22-6	CU	included in ITEM #7 Cable Assembly
5	009-107-18	Terminal	1	R-14-6	CU	included in ITEM #7 Cable Assembly
6	009-116-10	Terminal	2	R-2-4	CU	included in ITEM #7 Cable Assembly
7	001-007-68	Cabletyre Cable Set (15m)460V-60Hz(USA)	1	2PNCTFMulti-core9Cx22mm2	No.5	
8	011-101-19	Shackle	1	6mm	SS	
9	095-100-18	Chain	1	d5(9-Link)	SS	
10	072-108-44	Eye Bolt	2	M30	SS	
11	140-056-53	Hex.Bolt	4	M8x30	SUS304	included in ITEM #7 Cable Assembly
12	141-005-18	Hex.Nut	4	M8	SUS304	included in ITEM #7 Cable Assembly
13	003-106-19	Gland	1	No.5	FC	included in ITEM #7 Cable Assembly
14	004-170-17	Cable Bush	1	d39.5xd58.5x22l	CR	included in ITEM #7 Cable Assembly
15	005-106-28	Bush Washer	1	d42xd57x3.2t	SPC	included in ITEM #7 Cable Assembly
16	006-103-28	Stuffing Box	1	No.5	FC	included in ITEM #7 Cable Assembly
17	140-076-17	Hex.Bolt	4	M10x30	SUS304	
18	142-164-19	Spring Washer	4	M10	SUS304	
19	122-264-18	O-Ring	1	140xd3.5	NBR	*
20	008-105-13	Mould Cover	1	No.3	NBR	included in ITEM #7 Cable Assembly
21	003-149-14	Gland (Lower)	1	No.5	FC	included in ITEM #7 Cable Assembly
22	140-033-12	Hex.Bolt	4	M6x16	SUS304	
23	141-004-59	Hex.Nut	6	M6	SWRM	
24	140-029-28	Hex.Bolt	6	M6x10	SWRM	
25	009-168-17	Terminal	6	R-22-S6	CU	included in ITEM #7 Cable Assembly
26	009-106-17	Terminal	6	R-8-6	CU	
27	143-041-12	Pan Screw	1	M6x8	SWRM	
28	009-107-18	Terminal	1	R-14-6	CU	included in ITEM #7 Cable Assembly
29	009-115-19	Connector	2	PC-4020F		
30	009-114-18	Connector	2	PC-4020M		included in ITEM #7 Cable Assembly
31	002-115-18	Heat Shrink Tube (Sold per meter)	m	EVA(d16.5x1t)	(V/m)	
32	002-116-19	Heat Shrink Tube (Sold per meter)	m	A4(d20x0.35t)	(V/m)	
33	141-008-11	Hex.Nut	6	M16	SUS304	
34	142-166-11	Spring Washer	6	M16	SUS304	
35	144-436-24	Stud Bolt	6	M16x45(28/24)(JIS)	SUS304	
36	037-362-23	Center-Flange Discharge Pipe	1	LH837/875	SGP+SS	
37	121-500-16	Packing	1	LH637/875	THREE SHEET	*
38	127-259-15	Stay (Right)	1	LH837/845 (Right)	SS	

PARTS LIST		HI PRESSURE DEWATERING PUMP			1/30/2018	
ITEM	PART No.	DESCRIPTION	QTY	SIZE	MATERIAL	NOTES
39	140-126-13	Hex.Bolt	2	M16x50	SUS304	
40	140-124-11	Hex.Bolt	2	M16x40	SUS304	
41	142-166-11	Spring Washer	2	M16	SUS304	
42	142-166-11	Spring Washer	2	M16	SUS304	
43	141-008-11	Hex.Nut	2	M16	SUS304	
44	127-260-19	Stay (Left)	1	LH837/845 (Left)	SS	
46	035-113-18	Oil Plug	1	M12x14	SUS304	
46	121-247-12	Packing	1	d12.3xd18x2t	PE	*
47	140-093-10	Hex.Bolt	2	M10x120	SUS304	
48	142-164-19	Spring Washer	2	M10	SUS304	
49	142-297-12	Seal Washer	2	SM-10	SUS+NBR	*
50	140-076-17	Hex.Bolt	1	M10x30	SUS304	
51	142-164-19	Spring Washer	1	M10	SUS304	
52	140-130-10	Hex.Bolt	6	M16x70	SUS304	
53	142-166-11	Spring Washer	6	M16	SUS304	
54	051-231-13	Motor Head Cover	1		FC	
55	122-503-12	O-Ring	1	435xd6	NBR	*
56	122-344-13	O-Ring	1	234.3xd5.7	NBR	*
57	016-115-11	Lead Wire Protection Bush	1	GH-645/845(for 5 cores)	SBR	
58	016-112-18	Lead Wire Protection Bush	1	GH-645/845(for 3 cores)	SBR	
59	140-128-15	Hex.Bolt	6	M16x60	SUS304	
60	142-166-11	Spring Washer	6	M16	SUS304	
61	050-340-13	Motor Bracket	1		FC	
62	122-305-12	O-Ring	1	442xd6	NBR	*
63	142-280-12	Wave Washer	1	6310	SK5	
64	052-113-11	Bearing	1	6310ZZC3		
65	122-133-17	O-Ring	1	G-110(109.4xd3.1)	NBR	*
66	065-191-13	Outer Cover	1	GH-37/45KW	SS	
67	055-721-17	Rotor	1Set			
68	147-056-12	Impeller Key	1	10x8x50L	SUS420	
69	053-309-19	Motor Protector	3	9700K-46-215	(H)	
70		Stator 460V-60Hz(USA)	1Set			
		Stator 575V-60Hz(USA)	1Set			
71	122-107-12	O-Ring	1	P-315(314.5xd8.5)	NBR	*
72	064-391-12	Motor Frame	1		FC	
73	122-259-10	O-Ring	1	12xd3	NBR	*
74	144-490-13	Stator Set Bolt	1	M12(B=21)	SUS403	
75	122-151-11	O-Ring	1	G-200(199.3xd5.7)	NBR	*

PARTS LIST		HI PRESSURE DEWATERING PUMP			1/30/2018	
ITEM	PART No.	DESCRIPTION	QTY	SIZE	MATERIAL	NOTES
76	122-159-19	O-Ring	1	G-280(279.3xd5.7)	NBR	*
77	140-054-48	Hex.Bolt	4	M8x20	SWRM	
78	062-178-15	Bearing Fixing Plate	1		SS	
79	052-145-12	Bearing	1Set	6314ZZD2C3		
80	142-247-17	Bearing Washer	1	AW14	SPCC	
81	141-079-13	Bearing Nut	1	AN14	SS	
82	026-272-18	Oil Seal	1	SC-50689	NBR	
83	122-305-12	O-Ring	1	442xd6	NBR	*
84	140-103-14	Hex.Bolt	6	M12x60	SUS304	
85	142-165-10	Spring Washer	6	M12	SUS304	
86	060-417-13	Bearing Housing	1		FC	
87	035-113-18	Oil Plug	2	M12x14	SUS304	
88	121-247-12	Packing	2	d12.3xd18x2t	PE	*
89	122-305-12	O-Ring	1	442xd6	NBR	*
90	142-166-11	Spring Washer	6	M16	SUS304	
91	140-127-14	Hex.Bolt	6	M16x55	SUS304	
92	025-000-04	Mechanical Seal	1	HT-4550N	SiC	
93	143-070-23	Pan Screw	2	M5x6	SWRM	
94	030-136-12	Oil Lifter	1	HT-4550	Resin	
95	143-070-10	Pan Screw	6	M5x6	SWRM	
96	030-145-14	Seal Stopper	1	HT-4550	SPCC	
97	122-282-12	O-Ring	1	295xd4	NBR	*
98	029-346-13	Oil Casing	1	LH-37/45KW	FC	
99	142-165-10	Spring Washer	6	M12	SUS304	
100	140-097-14	Hex.Bolt	6	M12x30	SUS304	
101	122-282-12	O-Ring	1	295xd4	NBR	*
102	071-119-16	Shaft Sleeve	1	GH-370H/L	SUS403	
103	020A8312	Pump Casing	1	LH837/845(w/Labyrinth Ring)	FC	
104	026-130-13	Oil Seal	1	TCN-487012	NBR	
105	071-121-11	Shaft Sleeve	1	GH-370H/L	SUS403	
106	040-126-10	Impeller Shim		d41.5xd59x0.3t	SUS304	
107	021-410-28	Impeller (60Hz)	1	LH845-60	HiCrFC	
108	047-107-29	Impeller Thread Protect.Cover	1	No.6(33)	SUS304	
109	142-171-19	Spring Washer	1	M30	SUS304	
110	157-022-10	Impeller Nut	1	M30,P3.5(B=46,Hex.Cap Nut)	SUS304	
111	033-124-16	Suction Mouth Ring	1Set	GH-837	HiCrFC+FC	
112	122-246-14	O-Ring	1	180xd3.1	NBR	*
113	122-306-13	O-Ring	1	305xd5	NBR	*

PARTS LIST		HI PRESSURE DEWATERING PUMP			1/30/2018	
ITEM	PART No.	DESCRIPTION	QTY	SIZE	MATERIAL	NOTES
114	022-587-17	Suction Cover	1	GH-637	FC	
115	142-165-10	Spring Washer	6	M12	SUS304	
116	140-097-14	Hex.Bolt	6	M12x30	SUS304	
117	142-163-18	Spring Washer	3	M8	SUS304	
118	141-005-18	Hex.Nut	3	M8	SUS304	
119	140-058-42	Hex.Bolt	3	M8x40	SUS304	
120	141-005-18	Hex.Nut	3	M8	SUS304	
121	140-055-10	Hex.Bolt	3	M8x25	SUS304	
122	144-123-12	Stud Bolt	3	M12x120(20/20)	SUS403	
123	023-230-15	Strainer Stand	1Set	GH-370/450L	SS	
124	142-165-10	Spring Washer	3	M12	SUS304	
125	141-007-10	Hex.Nut	3	M12	SUS304	
126	141-007-10	Hex.Nut	3	M12	SUS304	
127	142-129-12	Plain Washer	3	M12	SUS304	
128	142-165-10	Spring Washer	3	M12	SUS304	
129	043-102-19	Cathodic Protection Plate	3	AB-1HS(75x70x20t)	Al	
130	140-096-13	Hex.Bolt	3	M12x25	SUS304	
		<NPT Flange Version>				
	048-000-52	Screwed Flange	1	NPT-8(JIS10K)	FC	
	121-109-24	Packing	1	JIS10Kx200mm	NR	
	140-155-11	Hex.Bolt	12	M20x85	SUS304	
	142-168-13	Spring Washer	12	M20	SUS304	
	141-009-12	Hex.Nut	12	M20	SUS304	
	173-511-11	Packing O-Ring Set	1Set	(Marked by *)		
19	122-264-18	O-Ring (S.Box)	1	140xd3.5	NBR	*
37	121-500-16	Packing (Discharge Pipe/Head Cover)	1	LH637/875	THREE SHEET	*
46	121-247-12	Packing (Air Tightness Test Plug)	1	d12.3xd18x2t	PE	*
49	142-297-12	Seal Washer (Motor Head Cover Bolt)	2	SM-10	SUS+NBR	*
55	122-503-12	O-Ring (Head Cover/M.Bracket)	1	435xd6	NBR	*
56	122-344-13	O-Ring (Head Cover/M.Bracket)	1	234.3xd5.7	NBR	*
62	122-305-12	O-Ring (M.Bracket/Out.Cover)	1	442xd6	NBR	*
65	122-133-17	O-Ring (Upp. Bearing)	1	G-110(109.4xd3.1)	NBR	*
71	122-107-12	O-Ring (M.Bracket/M.Frame)	1	P-315(314.5xd8.5)	NBR	*
73	122-259-10	O-Ring (Stator Set Bolt)	1	12xd3	NBR	*
75	122-151-11	O-Ring (M.Frame/Brg.Housing)	1	G-200(199.3xd5.7)	NBR	*
76	122-159-19	O-Ring (M.Frame/Brg.Housing)	1	G-280(279.3xd5.7)	NBR	*
83	122-305-12	O-Ring (Out.Cover/Brg.Housing)	1	442xd6	NBR	*
88	121-247-12	Packing (Oil Plug)	2	d12.3xd18x2t	PE	*



MODEL LH845-60

PARTS LIST		HI PRESSURE DEWATERING PUMP			1/30/2018	
ITEM	PART No.	DESCRIPTION	QTY	SIZE	MATERIAL	NOTES
89	122-305-12	O-Ring (Brq.Housing/P.Casing)	1	442xd6	NBR	*
97	122-282-12	O-Ring (Brq.Housing/O.Casing)	1	295xd4	NBR	*
101	122-282-12	O-Ring (O.Casing/P.Casing)	1	295xd4	NBR	*
112	122-246-14	O-Ring (Suction Mouth Ring/S.Cover)	1	180xd3.1	NBR	*
113	122-306-13	O-Ring (P.Casing/S.Cover)	1	305xd5	NBR	*
		Lubricant		Turbine Oil VG32 4,800ml		
	183-011-17	Impeller Puller	1	A No.6 2"	FC	

* Indicates items included in set

PARTS LIST		HI PRESSURE DEWATERING PUMP				1/30/2018
ITEM	PART No.	DESCRIPTION	QTY	SIZE	MATERIAL	NOTES

EXPLODED VIEW

LH845-50/60

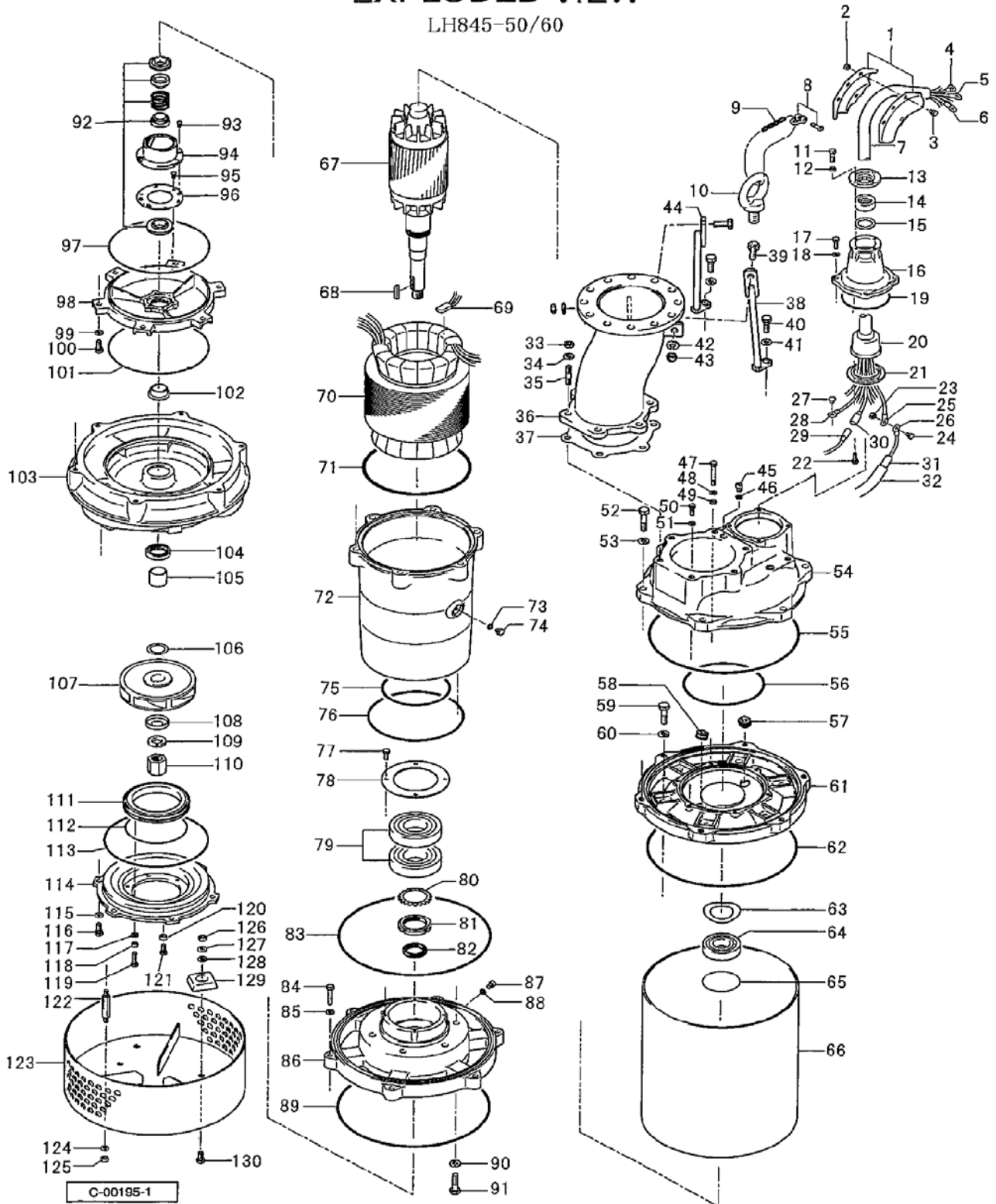

* Indicates items included in set