

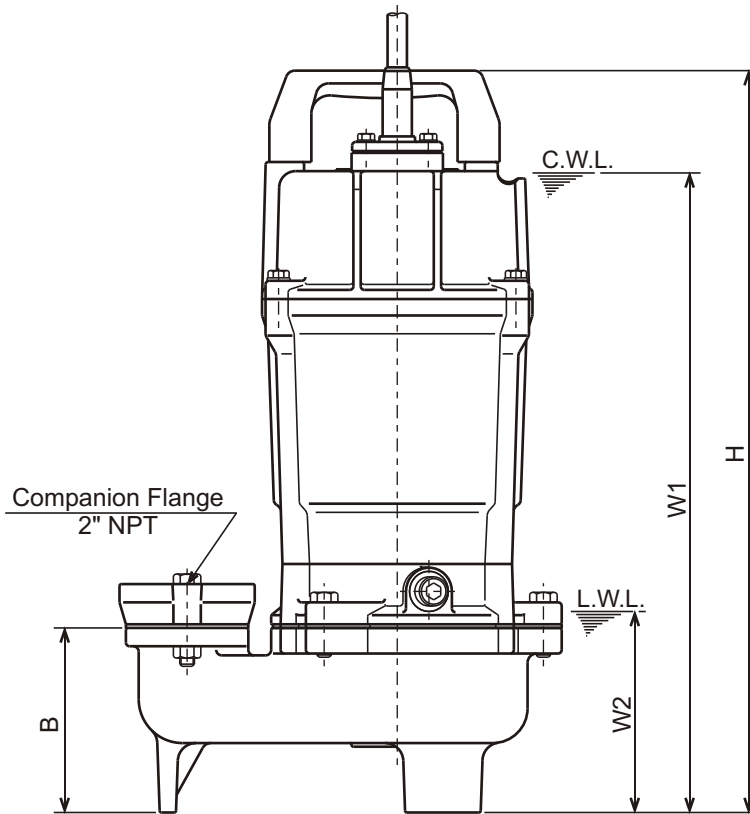

UT - SERIES
SUBMERSIBLE SEMI-VORTEX-SEWAGE PUMPS

DIMENSIONS

50UT2.75S-61

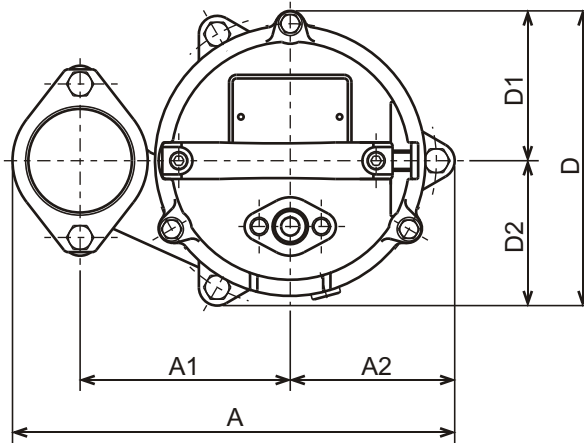

C.W.L. :Continuous running Water Level
 L.W.L. :Lowest running Water Level

DIMENSIONS:USCS (Inch)

Model	HP	NOM. SIZE	Pump & Motor								C.W.L.	L.W.L.	Wt. (lbs.)
			A	A1	A2	B	D	D1	D2	H	W1	W2	
50UT2.75S-61	1	2"	9 1/2	4 1/2	3 9/16	4	6 3/8	3 1/4	3 1/8	16	13 3/4	4 3/8	37

DIMENSIONS:METRIC (mm)

Model	kW	NOM. SIZE	Pump & Motor								C.W.L.	L.W.L.	Wt. (kg)
			A	A1	A2	B	D	D1	D2	H	W1	W2	
50UT2.75S-61	0.75	50	242	115	90	101	161	82	79	406	350	110	17.0



UT - SERIES SUBMERSIBLE SEMI - VORTEX - SEWAGE PUMPS

PERFORMANCE CURVE

MODEL	BORE	HP	KW	RPM	SOLIDS DIA	LIQUID	SG.	VISCOSITY	TEMP.
50UT(Z)2.75S -61	2" / 50mm	1	0.75	3424	1.4" / 36mm	Water	1.0	1.123 cSt.	60°F
PUMP TYPE	PHASE	VOLTAGE	AMPERAGE	HZ	STARTING METHOD	INS. CLASS			
SUBMERSIBLE SEMI - VORTEX - SEWAGE	Single	110/115/120 /220	10.2/9.9/9.6 /5.2	60	Capacitor-Start	E			
CURVE No.	DATE	PHASE	VOLTAGE	AMPERAGE	HZ	STARTING METHOD	INS. CLASS		
-	-	-	-	-	-	-	-		

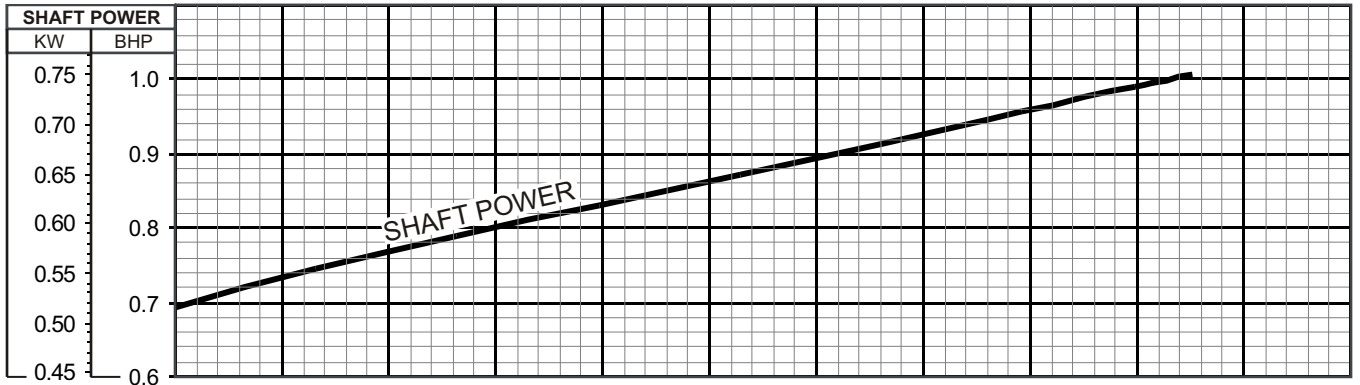
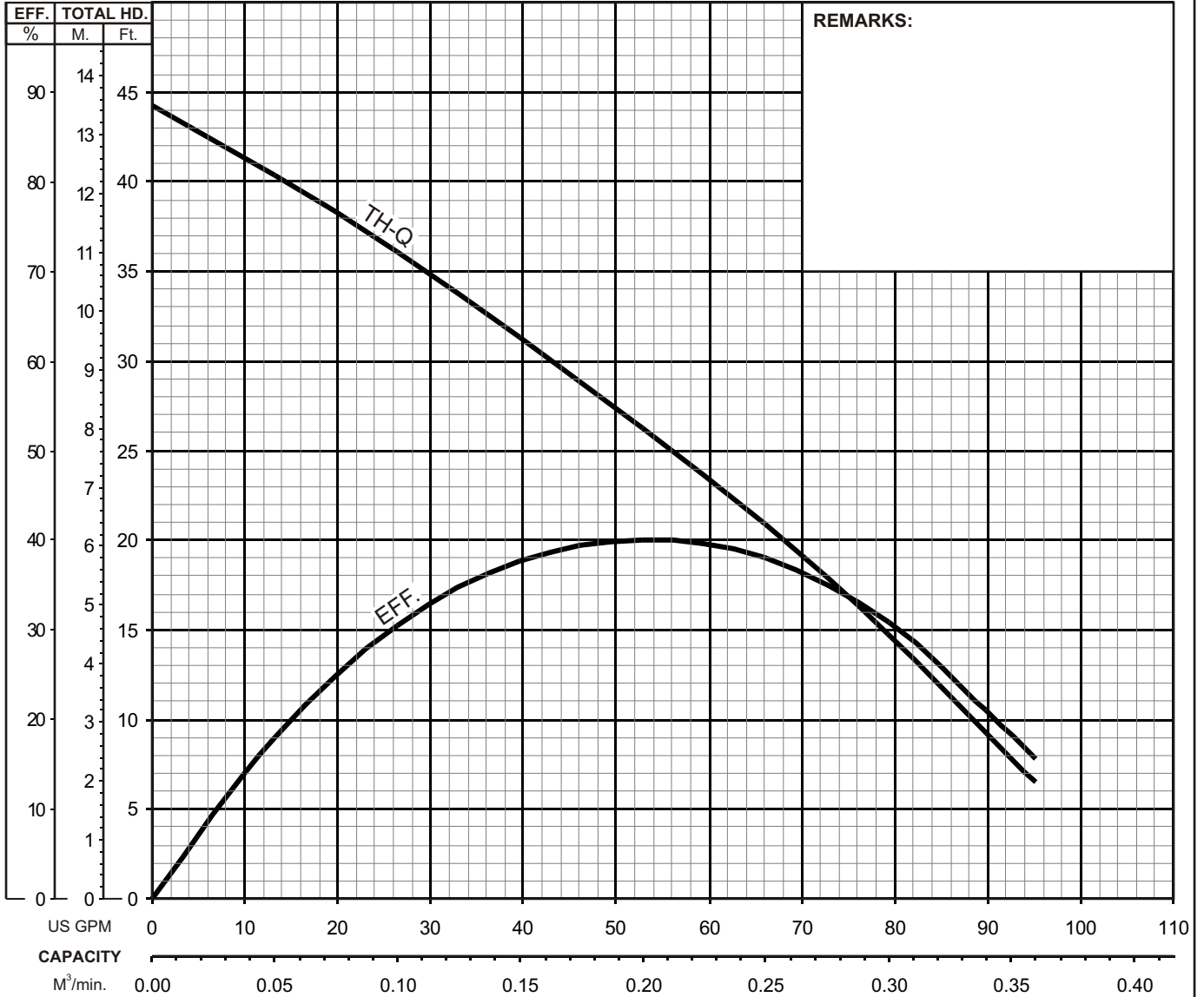



UT - SERIES
SUBMERSIBLE SEMI-VORTEX-SEWAGE PUMPS

SECTIONAL VIEW

50UT2.75S-61

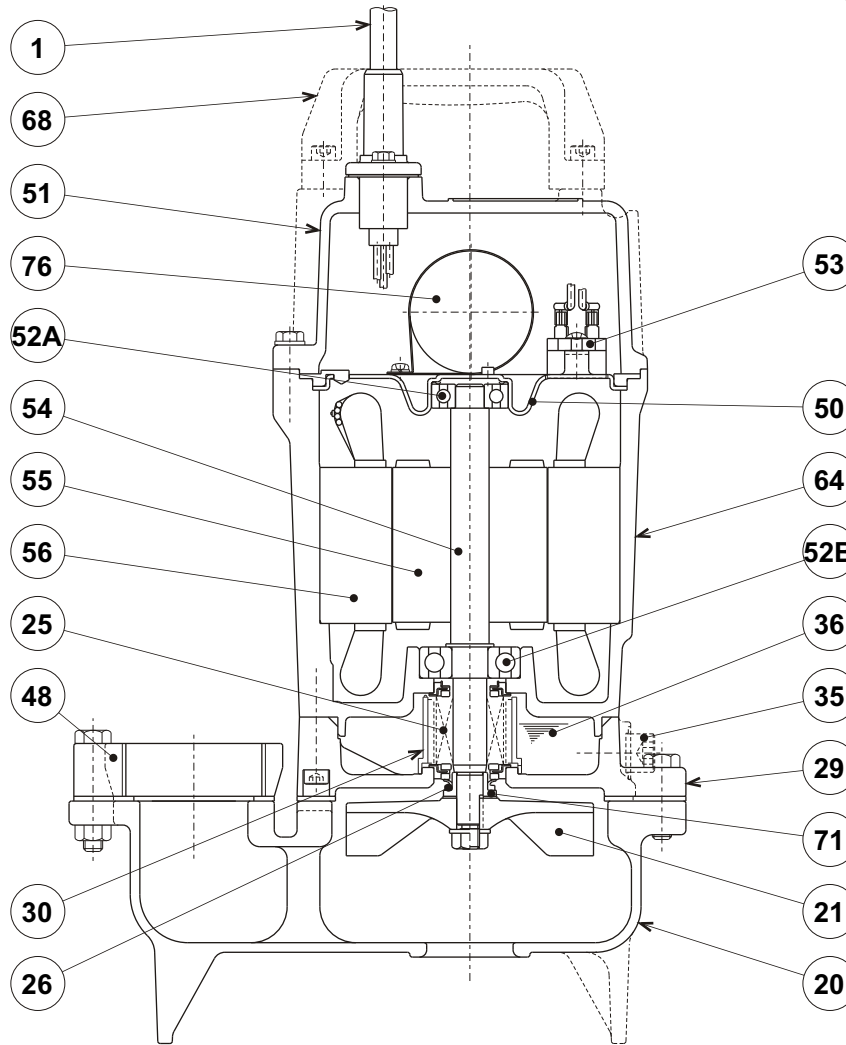

ITEM#	DESCRIPTION	MAIN MATERIAL / NOTE	RELATED ASTM, AISI CODE	RELATED EN CODE	Q'TY
1	Power Cable	PVC Sheath AWG14/3-32ft			1
20	Pump Casing	Cast Iron	A48M Class30B	EN 1561 GJL-200	1
21	Impeller	PPO Resin w/GF20			1
25	Mechanical Seal	Silicon Carbide / W-14VL			1
26	V-Ring	Nitrile Butadiene Rubber			1
29	Oil Casing	Cast Iron	A48M Class30B	EN 1561 GJL-200	1
30	Oil Lifter	PBT Resin			1
35	Oil Plug	Stainless Steel	S 30400	1.4301	1
36	Lubricant	Turbine Oil ISO VG32 or SAE10W-20			
48	Companion Flange	Cast Iron / NPT 2"	A48M Class30B	EN 1561 GJL-200	1
50	Motor Bracket	Steel (Electro-Galvanized)	A591	EN 10152	1
51	Motor Head Cover	Cast Iron	A48M Class30B	EN 1561 GJL-200	1
52A	Upper Bearing	#6201ZZC3			1
52B	Lower Bearing	#6302ZZC3			1
53	Motor Protector				1
54	Shaft	Stainless Steel	S 40300	1.4000	1
55	Rotor				1
56	Stator				1
64	Motor Housing	Cast Iron	A48M Class30B	EN 1561 GJL-200	1
68	Handle	ABS Resin			1
71	Shaft Sleeve	Stainless Steel	S 30400	1.4301	1
76	Capacitor				1

PARTS LIST		SEWAGE & WASTEWATER PUMP			12/15/2016	
ITEM	PART No.	DESCRIPTION	QTY	SIZE	MATERIAL	NOTES
1	001-471-12	Cabtyre Cable Set (32') 110V (USA)	1	VCT3Cx2.0mm2	LB	
	001-443-31	Cabtyre Cable Set (32') 220V (USA)	1	VCT3Cx2.0mm2	LB	
2	140-427-17	Hex.Bolt (w/Plain Washer)	2	M5x15	SUS304	
3	003-190-10	Gland	1		SUS316	
4	140-253-10	Hex.Socket Cap Bolt	2	M6x25	SUS304	
5	068-146-38	Handle	1	A	Resin	
6	140-396-16	Hex.Bolt (w/Plain Washer)	3	M6x20	SUS304	
7	051-000-40	Motor Head Cover	1		FC	
8	143-000-43	Truss Screw	2	M4x8	SWRM	
9		Motor Protector 110V-60Hz	1		(T.C)	
	053-001-69	Motor Protector 220V-60Hz	1	KA112-BAXL09	(T.C)	
10	121-000-84	Packing	1		NBR	*
11		Capacitor 110V-60Hz	1	SH-CAP,_MF-500VAC (four terminals)		
	076-000-41	Capacitor 220V-60Hz	1	SH-CAP,15MF-500VAC (four terminals)		
12	143-085-21	Pan Screw (w/Spring Washer)	1	M4x6	SWRM	
13	127-000-46	Capacitor Fixing Plate	1		SPC	
14	009-001-02	Earth Terminal	1Set	UL1015- AWG18,G/Y,L=160		
15	143-000-44	Pan Screw (w/Spring Washer)	1	M4x5	C3604	
16	050-000-61	Motor Bracket	1		SECD	
17	142-192-16	Wave Washer	1	6201(D=32,t=0.4)	SK5	
18	052-100-15	Bearing	1	6201ZZC3		
19	055-001-73	Rotor	1Set	w/Bearing		
20	061-180-17	Bearing Collar	1	d15.1xd20x1.6t	SS	
21	052-152-12	Bearing	1	6302ZZC3		
22		Stator 110V-60Hz	1Set			
	056-005-18	Stator 220V-60Hz	1Set			
23	064-000-94	Motor Frame	1		FC	*
24	025-291-10	Mechanical Seal	1	W-14VL	SiC+CCBN	
25	030-000-09	Oil Lifter	1	W-14VL	Resin	
26	122-133-17	O-Ring	1	G-110(109.4xd3.1)	NBR	*
27	140-056-11	Hex.Bolt	3	M8x30	SUS304	
28	029-000-58	Oil Casing	1	HS2.4(S)-52/62	FC	*
29	121-246-11	Packing	1	d10.3xd16x2t	PE	
30	035-124-12	Oil Plug	1	M10x15	SUS304	
31	121-000-20	Packing	1	HS-4E	NR	
32	140-256-13	Hex.Socket Cap Bolt	3	M6x35	SUS304	
33	071-292-14	Shaft Sleeve	1	LB3-250/480	SUS304	
34	142-354-18	Conical Spring Washer	1	d11.2xd22.5x0.8t	SUS304	
35	021G2821	Impeller (60Hz)	1	50UT2.75S-61	Resin	
36	142-127-10	Plain Washer	1	M8	SUS304	
37	141-005-18	Hex.Nut	1	M8	SUS304	
38	020-001-85	Pump Casing	1	40UT2.4S-51/61	FC	*
39	140-059-14	Hex.Bolt	2	M8x45	SUS304	
40	048-180-16	Screwed Flange	1	2" NPT (P.C.84)	FC	



MODEL **50UT2.75S-61**

PARTS LIST		SEWAGE & WASTEWATER PUMP				12/15/2016
ITEM	PART No.	DESCRIPTION	QTY	SIZE	MATERIAL	NOTES
41	121-138-19	Packing	1	LB(P.C.84)	NBR	
42	141-005-18	Hex.Nut	2	M8	SUS304	
	173-001-35	Packing O-Ring Set	1Set	(Marked by *)		
10	121-000-84	Packing (Head Cover/M.Frame)	1		NBR	*
23	122-133-17	O-Ring (M.Frame/O.Casing)	1	G-110(109.4xd3.1)	NBR	*
26	121-246-11	Packing (Oil Plug)	1	d10.3xd16x2t	PE	*
28	121-000-20	Packing (O.Casing/P.Casing)	1	HS-4E	NR	*
38	121-138-19	Packing (Hose Coupling)	1	LB(P.C.84)	NBR	*
		Lubricant		Turbine Oil VG32 160ml		

* Indicates items included in set

PARTS LIST		SEWAGE & WASTEWATER PUMP				12/15/2016
ITEM	PART No.	DESCRIPTION	QTY	SIZE	MATERIAL	NOTES

EXPLODED VIEW

50UT2.75S-51/61

